



Identification of Street Hydrants for Firefighting Purposes

FIRE SERVICES GUIDELINES



4 Table of Contents

1.0	Acknowledgements	3
2.0	Introduction	4
3.0	Definitions	5
4.0	Provision of Hydrant Identification	6
4.1	Scope of guidelines	6
4.2	Performance criteria	6
4.2.1	Identifiable as a hydrant	6
4.2.2	Identifiable by fire appliances from direction of approach	7
4.2.3	Exact location of hydrant is identified	7
4.2.4	Hydrant identification system integrity is maintained	7
4.2.5	Special area hydrant identification	8
4.3	Special Buildings	8
5.0	Identification Installation Requirements	9
5.1	General	9
5.1.1	Hydrant markings - General	9
5.1.2	Raised reflective road markers	10
5.1.3	Marker posts	11
5.1.4	Vertical surface hydrant markers	12
5.2	Above ground hydrants	13
5.2.1	General	13
5.2.2	Areas with sealed pavement road, kerb and channelling	14
5.2.3	Areas with sealed pavement road but no kerb and channelling	15
5.2.4	Areas with unsealed roads	16
5.2.5	Areas where hydrant is concealed	17
5.3	Below ground hydrants	18
5.3.1	Below ground hydrants identified by L type hydrant covers	18
5.3.2	Hydrant installed in roadways	19
5.3.3	Areas with sealed pavement road, kerb and channelling	20
5.3.4	Areas with sealed pavement road but no kerb and channelling	22
5.3.5	Areas with unsealed roads	23
5.3.6	Areas where hydrant may be concealed	24
6.0	Maintenance	25
Appendix	Application Requirements for Hydrants Identification Variation	26



1

1.0 Acknowledgements

Acknowledgements

The fire services Guidelines for the Identification of Street Hydrants for Firefighting Purposes were developed by CFA, Community Safety Directorate with the assistance of the Department of Sustainability and Environment and the Metropolitan Fire and Emergency Services Board.

The fire services gratefully acknowledge all the organizations who contributed to the development of these guidelines, including Crevet Pipelines Pty Ltd for providing the images for the front and back covers.

Disclaimer

Every effort has been made to ensure the information contained in this publication is free from error and/or omissions. No responsibility can be accepted by CFA, the Metropolitan Fire and Emergency Services Board, Department of Sustainability and Environment or their employees involved in the preparation of this publication, for any claims that may arise from a person acting on information contained herein.



2.0 Introduction

Hydrants provide the means for drawing water from mains. One of the key reasons for their installation on water mains is for use by fire services during firefighting operations for property protection and fire suppression. These operations may include all manner of fire service emergencies and other situations requiring access to water ranging from those involving residential dwellings to major bush fires.

The objective of these guidelines is to provide the preferred position of the fire services in Victoria, on the identification of street hydrants installed for firefighting purposes throughout the State. For the purpose of these guidelines the Victorian fire services are the Country Fire Authority (CFA), Department of Sustainability and Environment (DSE) and the Metropolitan Fire & Emergency Services Board (MFB).

The aim of these guidelines is to provide a reference source for water utilities (their consultants and contractors), municipalities and other parties responsible for provision and maintenance of identification components of street hydrants for firefighting purposes. They are provided to complement accepted water supply technical references such as the Water Industry Technical Standards (WITS) Manuals and appropriate National Codes. Importantly they ensure a move towards statewide consistency of hydrant identification.

In developing these guidelines, the fire services have been mindful of the financial considerations associated with the specification of particular identification systems and the ongoing maintenance.

NOTE: These guidelines **are not intended for the purpose of identifying** fire protection systems provided on private properties in accordance with the various Building regulations and codes that apply within Victoria.

Enquiries regarding the application of these guidelines should be directed to the relevant fire service.

CFA Area: the appropriate CFA Manager, Community Safety or CFA Community Safety Directorate, 8 Lakeside Drive, Burwood East on (03) 9262 8444. (PO Box 701, Mt Waverley, 3149)

MFB Area: the appropriate MFB Zone Command or MFB Fire Safety Department, 433 Smith Street, Fitzroy North on (03) 9420 3874.

DSE Area: the appropriate DSE District Fire Management Officer or DSE Fire Management, 6/240 Victoria Parade, East Melbourne on (03) 9412 4777.

3.0 Definitions

Above Ground Hydrant

Includes an L type hydrant, pillar hydrants, millcocks and dry riser.

Aesthetic or Historical Significance

A building that by way of its design is of aesthetic significance to the local community, or a building that has historical significance to the community.

Alpine Area

As defined in the Building Code of Australia, means land -

- (a) likely to be subject to significant snowfalls;
- (b) more than 1200 m above the Australian Height Datum.

Below Ground Hydrant

Includes ground ball and spring loaded hydrants (fire plug).

Bushfire Prone Area

An area designated by a municipality as having a level of risk of wildfire.

Country Fire Authority (CFA) Area

The area designated as the country area of Victoria within the Country Fire Authority Act 1958.

Hydrants

Any type provided on a pipeline/water main where water can be accessed for firefighting purposes and includes ground ball, L type, pillar hydrant or millcock.

Large Open Areas

A paved or concreted area within an urbanised environment that consists of a large open space. This includes facilities such as outdoor shopping malls and pedestrian walkways.

Metropolitan Fire Brigade (MFB) Area

The area designated as the metropolitan district within the Metropolitan Fire Brigade Act 1958.

Department of Sustainability and Environment (DSE) Area

The area designated as the fire protected area within the Forests Act 1958.

Relevant Fire Service

The Country Fire Authority (CFA), Department of Sustainability and Environment (DSE) or the Metropolitan Fire Brigade (MFB).

Valve Controlled Hydrant

A below ground hydrant which consists of a fire plug and associated isolation valve. These are generally installed on water mains with diameters greater than 300mm.

W.I.T.S.

Water Industry Technical Standards.



4.0 Provision of Hydrant Identification

4.1 Scope of guidelines

The following are recommendations for the identification of street hydrants for firefighting throughout Victoria. The objective is to ensure a high level of consistency that provides for efficient and effective location at any time.

4.2 Performance criteria

For a hydrant identification system to be successful it must satisfy all of the following performance criteria:

- it must ensure that the hydrant is identifiable as a hydrant;
- the system must ensure ease of location by fire appliances approaching from any direction;
- the exact location of hydrant must be determined; and
- it must be suitable for special areas such as bushfire prone areas, alpine areas and large open areas.

4.2.1 Identifiable as a hydrant

- (i) All hydrants are to be identified by a blue reflective material to ensure that the hydrant can be identified at night; and
- (ii) All post type markers and above ground hydrants are to have a red, non-reflective marking, around the top of the post, or the defined head of the above ground hydrant body or cover.

Explanatory notes

The standardisation of a colour to indicate hydrants ensures quick and easy location, and provides consistency throughout the state. Blue delineators have been utilised in the past therefore alleviating the need to change markings on many hydrants and also reducing possible confusion between these and other markers, such as those used for traffic management.

The use of a reflective material ensures the efficient location of any identifying marker at night.

The red top on hydrants, hydrant covers and markers posts ensures that they are positively identified as being for firefighting purposes, and provides for efficient identification during daytime operations.



4.2.2 Identifiable by fire appliances approaching from any direction

Hydrants are to be identified in such a way as to make the indicator visible from any direction of approach.

Explanatory notes:

By ensuring that the hydrant is indicated in some way so as to make it identifiable to responding crews from any direction of approach, the time required to locate it is reduced. It also permits the identification of hydrants from greater distances.

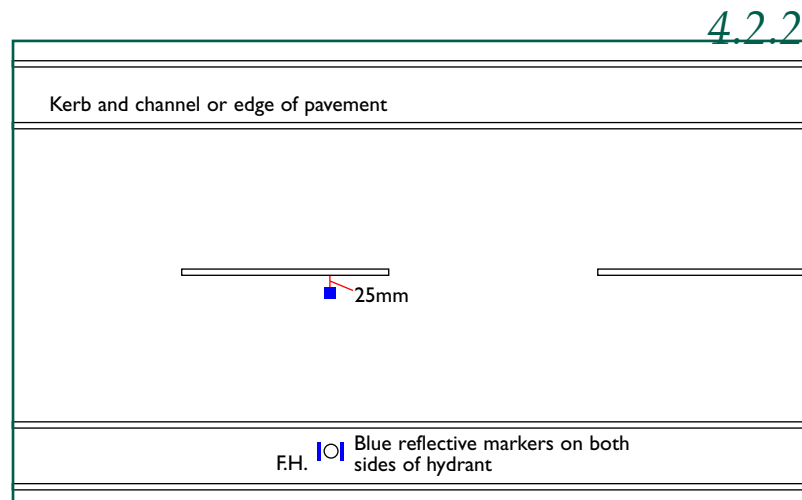

4.2.3 Exact location of hydrant is identified

Hydrants are to be identified in such a way as to ensure the exact location of the hydrant can be determined. The method utilised must take into account the location in relation to the roadway and the type of hydrant used.

Explanatory notes:

The purpose of this performance criteria is to ensure that hydrants are not just indicated on the roadway but have some form of marker adjacent to the hydrant, if some distance from the road. Consideration must be given to the fact that if hydrants are installed this way, maintenance programs may not always keep the indicator adjacent to the hydrant clear.

4.2.4 Hydrant identification system integrity is maintained

Hydrant identification systems should be constructed and installed in a manner that ensures that they cannot have their effectiveness reduced by vandalism.

Explanatory Notes:

Vandalism poses a significant threat to the continued integrity of hydrant identification systems and as such every effort should be made to reduce the likelihood of this occurring. Posts should be securely installed (eg. concreted or as per manufacturers specifications), covers and caps should be installed and replaced correctly after maintenance.

4.2.5 Special area hydrant identification

(i) Bushfire prone areas

Hydrants in designated bushfire prone areas are to be identified by a system which will not be adversely affected by the passage of fire.

Explanatory notes:

This performance criteria is appropriate to areas where the identification of hydrants after the passage of a wildfire would be necessary as firefighting operations move in reaction to the wildfire. Some traditional methods of hydrant identification do not perform well if exposed to fire, especially in areas where fuel levels are high.

(ii) Alpine areas

Hydrants in designated alpine areas are to be identified by a system which will not be adversely affected by the presence of snow.

Explanatory notes:

This performance criteria is appropriate to areas where the identification of hydrants will be, for parts of the year, hampered by the presence of snow.

(iii) Large open areas

Below ground hydrants in large open areas, where marker posts or other markers such as blue raised reflective road markers are either impractical or unsuitable, are to be identified by a system which will provide adequate hydrant identification.

Explanatory notes:

This performance criteria is appropriate for use in large open areas such as outdoor shopping centre malls, large paved areas and the like. Due to urbanisation of these areas, there is still a requirement for appropriate hydrant identification. The physical presence of above ground hydrants ensures adequate identification is maintained. Whereas, the normal below ground hydrant identification systems become impractical due to the shop fronts and large paved areas within these sites.

4.3 Special buildings

In cases where hydrants are to be positioned near buildings of aesthetic or historical significance, variations to the identification requirements of these guidelines may be approved by the relevant fire service.

Explanatory notes:

This is applicable to areas where the installation of modern identification systems would not be complimentary to the surroundings. An application must be provided to the relevant fire service detailing the reason for the variation and the proposed identification system. The application must be made to the relevant fire service through the offices detailed on page 4 of these guidelines. Applications need to identify why compliance with these guidelines can not be achieved and the proposed alternative identification to be used.

Appendix A contains details which must be submitted to the relevant fire service.



5.0 Identification Installation Requirements

The following details relating to hydrants are divided into three sections:

General

– requirements that relate to all hydrant types;

Above ground hydrants

– identification installation requirements relative to above ground hydrants only (ie: L type hydrant, pillar hydrants, millcocks and dry riser); and

Below ground hydrants

– identification installation requirements relative to below ground hydrants only (ie: ground ball, spring loaded hydrants [fire plug] and valve controlled hydrants).

5.1 General

Total compliance with the applicable identification installation criteria of this section is deemed to satisfy the requirements of the relevant fire service, and as such no approval of the defined identification system is necessary.

However, this does not limit in any way other approval requirements which may be imposed from time to time, by the relevant fire service in relation to other matters associated with the identification of street hydrants for firefighting purposes.

5.1.1 Hydrant markings - General

- (i) All hydrants are to be identified by blue reflective markers each with a surface area of at least 50cm², and manufactured either generally or in accordance with the specific provisions of:
 - for reflective tape - of AS/NZS 1906.1 - 1993 - Retroreflective materials and devices for road traffic control purposes - Class I Retroreflective materials,
 - for post mounted discs - AS 1906.2 - 1981 - Retroreflective materials for road traffic control purposes - Retroreflective devices (non-pavement application); and
 - for raised reflective road markers - AS 1906.3 - 1992 - Retroreflective materials and devices for road traffic control purposes - Raised pavement markers (retroreflective and non-retro reflective).

The number and their location are as contained in these guidelines.

- (ii) All post type markers and above ground hydrants are to have a red, non-reflective marking of at least 200 mm around the top of the post, or the defined head of the above ground hydrant body or cover.
- (iv) The red, non-reflective marking is to be either factory pre-mixed Bristol Red, Dulux Wildfire Red or equivalent.



5.1.2

5.1.2 Raised reflective road markers

Blue raised reflective road markers, when used, must comply with AS 1906.3 - 1992 - Retroreflective materials and devices for road traffic control purposes - Raised pavement markers (retroreflective and non-retroreflective), and are to be installed 25mm from the centre line of the road for single carriageways on the hydrant side or 25mm from the lane marking line on the hydrant side from multiple carriageways and divided roads in accordance with figure 5.1.2.

5.1.2

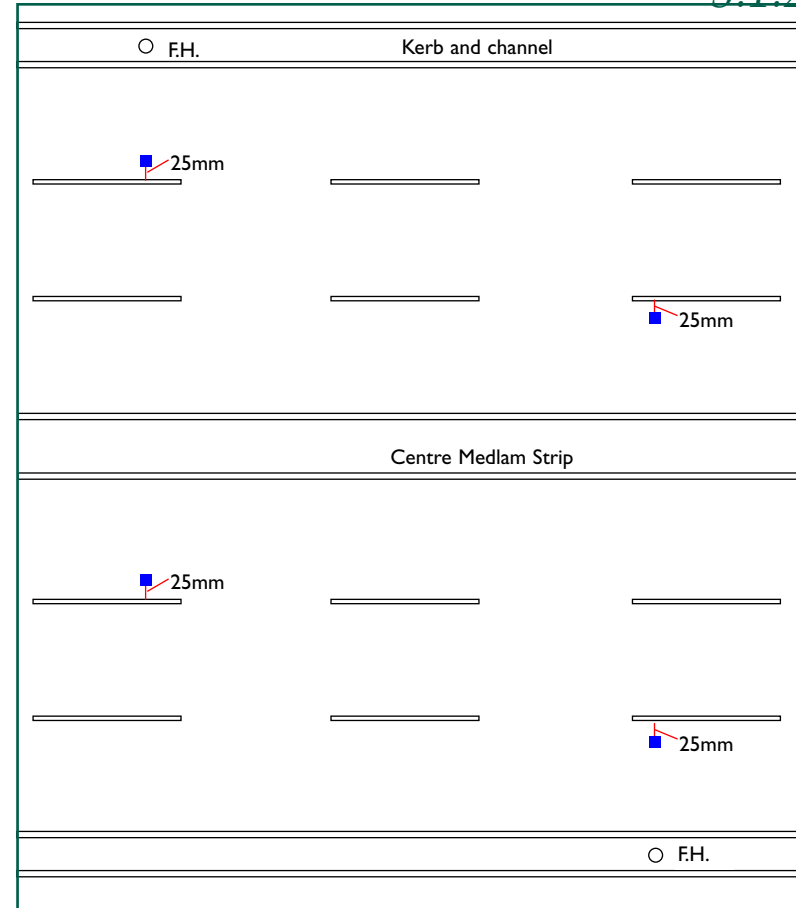

5.1.3 Marker posts

- (i) Marker posts used for the identification of any type of hydrant are to have a red non-reflective top of at least 200 mm in length, blue reflective markers in accordance with section 5.1.1(i), and be installed in such a manner as to have the reflective markers visible to the direction of approach
- (ii) Marker posts are to be at least 1000 mm in height above the finished ground level and be installed in such a manner as to ensure they will not be easily removed (eg. concreted or to manufactures specification)
- (iii) Marker posts used to identify hydrants are to be installed not less than 500 mm and not more than 750 mm from the hydrant or they must include a method of indicating the direction and distance to the hydrant
- (iv) Any marker posts which have a tapered top designed to indicate the direction of the hydrant must be installed with the taper facing towards the hydrant
- (v) Any marker post associated with the identification of any hydrant (either above or below ground) installed in a bushfire prone area is to be of metal, concrete or some other material that will not be affected by the passage of fire.

5.1.3

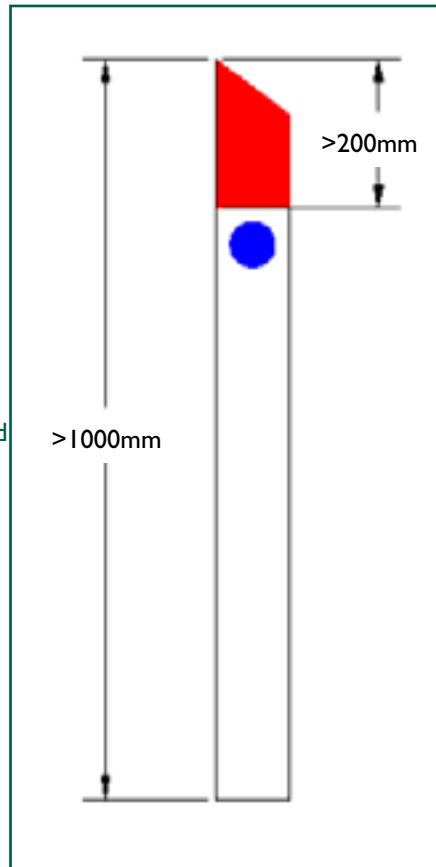

Explanatory notes:

The purpose of specifying these materials for the construction of marker posts is to ensure that they survive the passage of wildfire intact and can be identified after the firefront has passed.

This ensures that firefighters are not hindered in any way in identifying reticulated water sources.

5.1.4 Vertical Surface Hydrant Indicators

- (i) Vertical surface hydrant indicators are primarily for identification of below ground hydrants installed in large open areas (see definition), where other identification systems are unsuitable. This identification system must consist of both a primary and a secondary marker.
- (ii) Indicators used are to be either:
- a zinc coated steel sheet, pre-painted white with blue reflective material (in accordance with 5.1.1(i)) fixed in the centre of the marker. This type of marker is to be nailed onto the surface; or
 - a white scotchcal vinyl sheet with blue reflective material (in accordance with 5.1.1(i)) fixed in the centre of the marker. This type of marker is to be fixed onto the surface with adhesive backing.
- (ii) The blue reflective material on vertical surface hydrant indicators are to be in the following two sizes. Primary markers are to be 150mm x 225mm and secondary markers are to be 150mm x 112mm.
- (iii) The primary marker is to be installed on a vertical surface directly in front of the hydrant location in a position which identifies it from the most likely direction of approach.
- The secondary marker is to be installed on the off side of the vertical surface (where possible) to indicate the location of the primary marker.
- (iv) The preferred height of installation is between 1800mm and 2000mm, however this height may be varied depending on the location of the installation in consultation with the relevant fire service.
- The indicators are required to be installed at an appropriate distance from the hydrant but must still identify it.

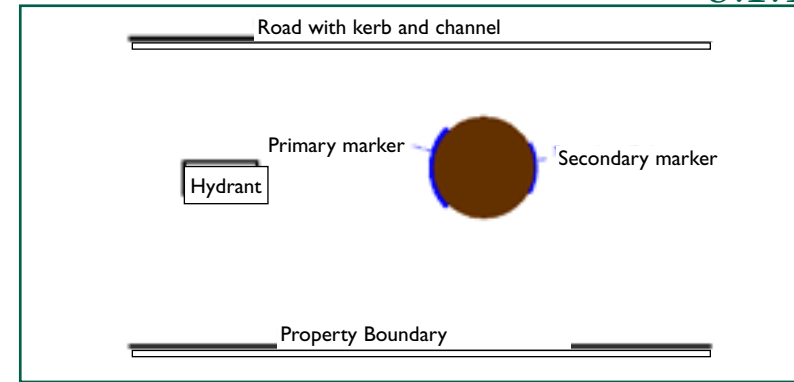

Explanatory notes:

Vertical surface hydrant markers have the advantage of being able to be affixed to a variety of surfaces. Therefore, in large open areas where it is unsuitable to use normal below ground hydrant identification systems, such as outdoor shopping malls and large paved or concreted areas, their use is ideal.

These indicators come in two forms: primary and secondary. Primary markers have a larger reflective surface and are for indicating the location of the hydrant. The secondary marker has a smaller reflective surface and its main function is to indicate the location of the primary marker. The installation of the secondary marker on the offside of the surface where the primary marker is installed, ensures ease of location of the primary marker and the identification of the hydrant is achieved.

This identification method is similar to the system used by the MFB which is installed and maintained by MFB personnel. Their application is for all hydrants installed within the Metropolitan Fire District. The system indicated within these guidelines is not for the identification purpose of all hydrants, just those that cannot be identified via the normal identification requirements. This system can be adapted for use within large open areas, where there are permanent objects that can be used to affix the indicators on. However, the use of these markers should not be generally used in place of other requirements outlined in these guidelines.

5.2 Above Ground Hydrants

5.2.1 General

- (i) All above ground hydrants installed for the purpose of providing water for firefighting purposes are to have incorporated on them the following method of identification:

- L type hydrants Fig 5.2.1(a) are to have a cover with a red top and blue reflective markers complying with section 5.1.1(i),
- Pillar hydrants Fig 5.2.1(b) are to have a red non-reflective top and blue reflective markers complying with section 5.1.1(i),
- Millcocks Fig 5.2.1(c) provided as street hydrants are to have a red non-reflective top of at least 200 mm and blue reflective markers complying with section 5.1.1(i),
- Any above ground hydrant installed in an alpine area, and not enclosed in a cabinet, is to have a red non-reflective body or riser and blue reflective markers complying with section 5.1.1(i). If installed in a cabinet, the cabinet is to be red in colour and have blue reflective strips complying with section 5.1.1(i) on the front and both sides of the cabinet- see Fig 5.2.1(d)

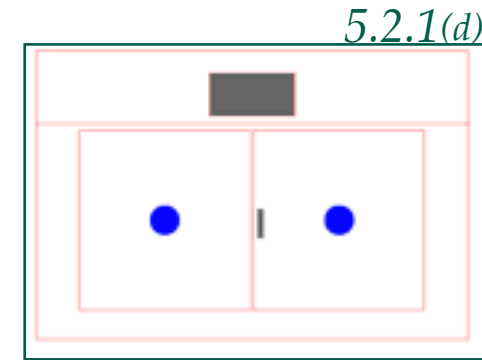
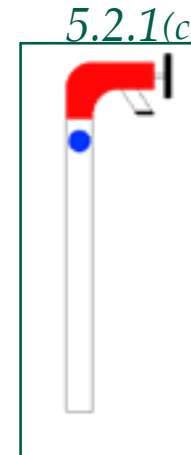
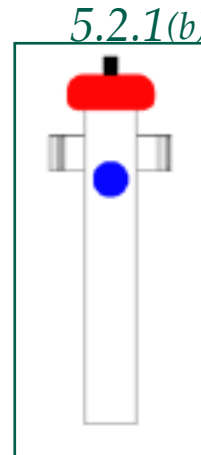
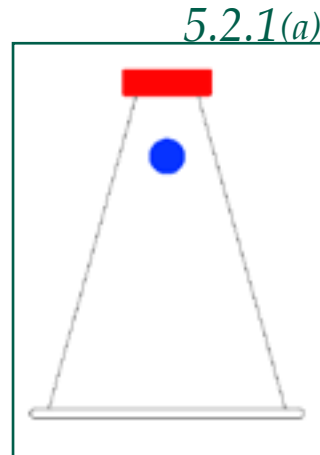

Explanatory notes:

The purpose of ensuring that hydrants for firefighting purpose are indicated by a red top is to reduce confusion with those hydrants placed on water mains for maintenance purposes. The reflective blue markers provide for positive identification of the hydrant at night.

It must be noted that black top hydrants are not provided for nor should be used for firefighting purposes without permission of the appropriate water supplier.

In alpine areas, the requirement for a red body or riser when hydrants are not installed in cabinets and the use of red cabinets is to ensure positive identification when surrounded by snow. The reflective strips again aid in locating the hydrants at night.

5.2.2 Areas with sealed pavement road, kerb and channelling

In addition to the identification requirements on the above ground hydrant cover, riser or body, hydrants installed in areas with sealed pavement roads, kerbing and channelling, are to be identified by a blue raised reflective road marker.

Explanatory notes:

The use of blue raised reflective road markers is already widespread and where appropriate provides one of the most effective methods of identifying the position of hydrants. The use of these markers in addition to the identification on the cover or body of the above ground hydrant, ensures that the location can be determined even if some obstacle, for example a car, is blocking the line of sight of firefighting personnel.

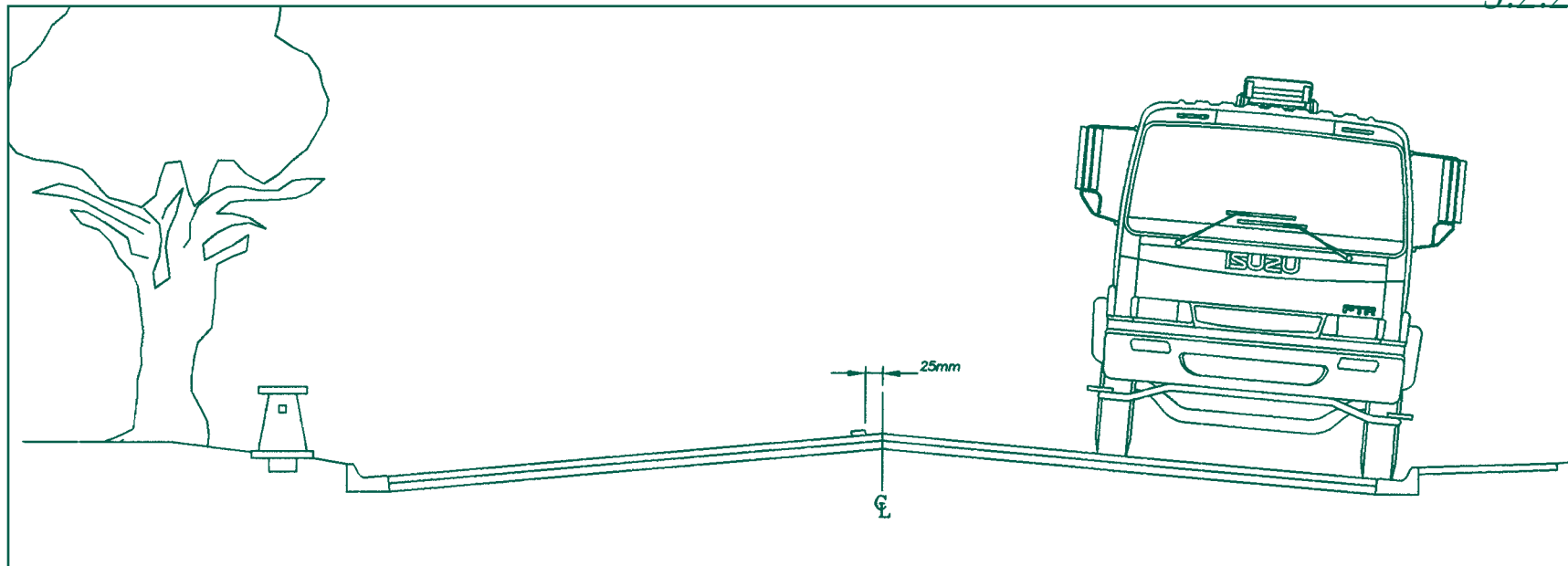

5.2.3 Areas with sealed pavement road, but no kerb and channelling

In addition to the identification requirements on the above ground hydrant cover, riser or body, above ground hydrants installed in areas with sealed pavement roads but no kerb and channelling are to be identified by:

- in areas with urban development - a blue raised reflective road marker; and
- in rural areas (if more than six metres from the normally maintained road edge) - a marker post (in accordance with 5.1.3) installed in such a position as to ensure that approaching fire appliances are directed to the location of the hydrant.

Explanatory notes:

The specification of blue raised reflective road markers in urban areas ensures consistency in environments with structural development where the likelihood of obstructions is increased. Whilst, the provision of marker posts in rural areas, if the hydrant is some distance from the road edge, ensures these hydrants can be efficiently located.

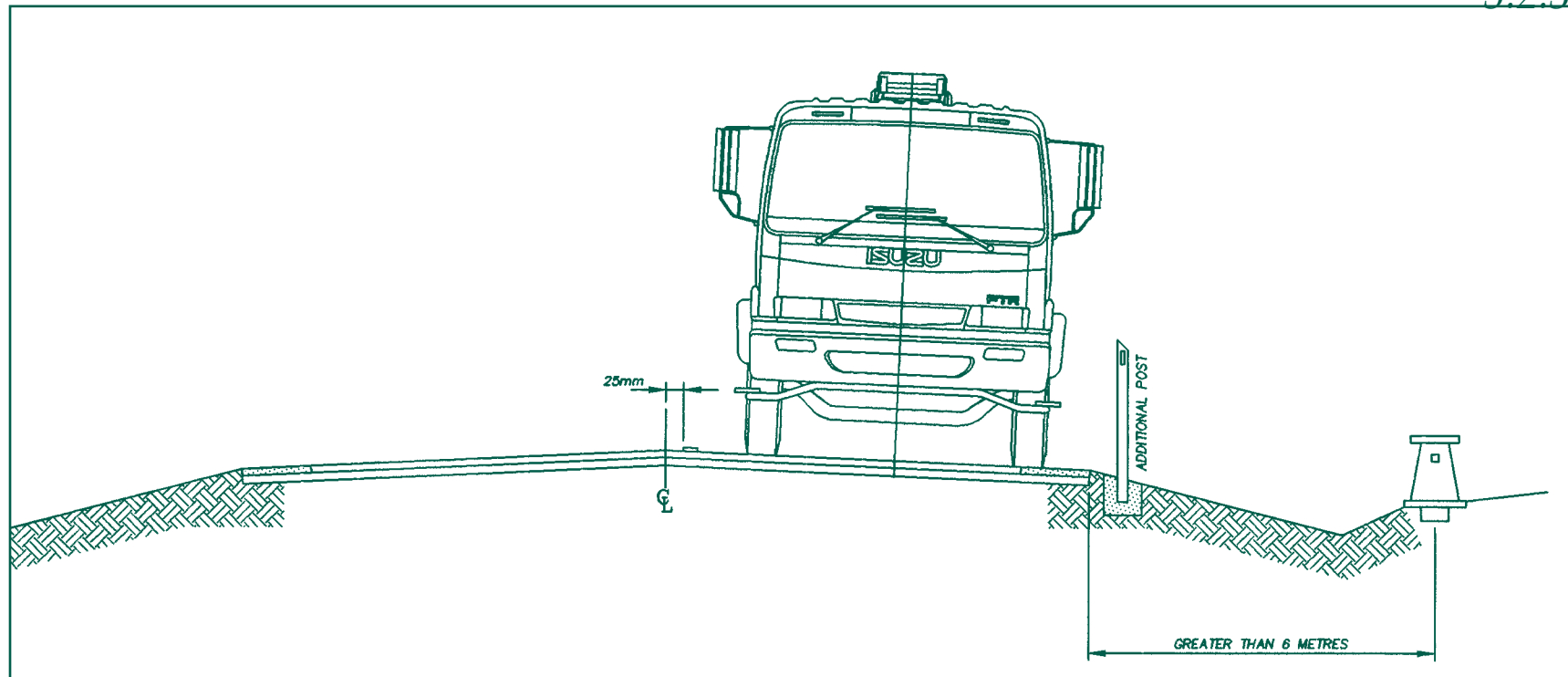

5.2.4 Areas with unsealed roads

In areas without sealed pavement roads, above ground hydrants, if more than six metres from the normally maintained edge of the road, are to identified by a marker post (in accordance with 5.1.3) installed in such a position as to ensure that approaching fire appliances are directed to the location of the hydrant. This marker post is in addition to the standard identification requirements for the above ground hydrant cover, riser or body.

Explanatory notes:

Given the nature of the road surface, blue raised reflective road markers cannot be used in this application and subsequently marker posts offer the most appropriate method. It is expected that in these areas, if hydrants are less than six metres from the road edge they should be easily located (subject to clearing of undergrowth or other obstacles, which should be addressed as part of ongoing maintenance) however, if greater than this distance, it maybe difficult to locate the hydrant.

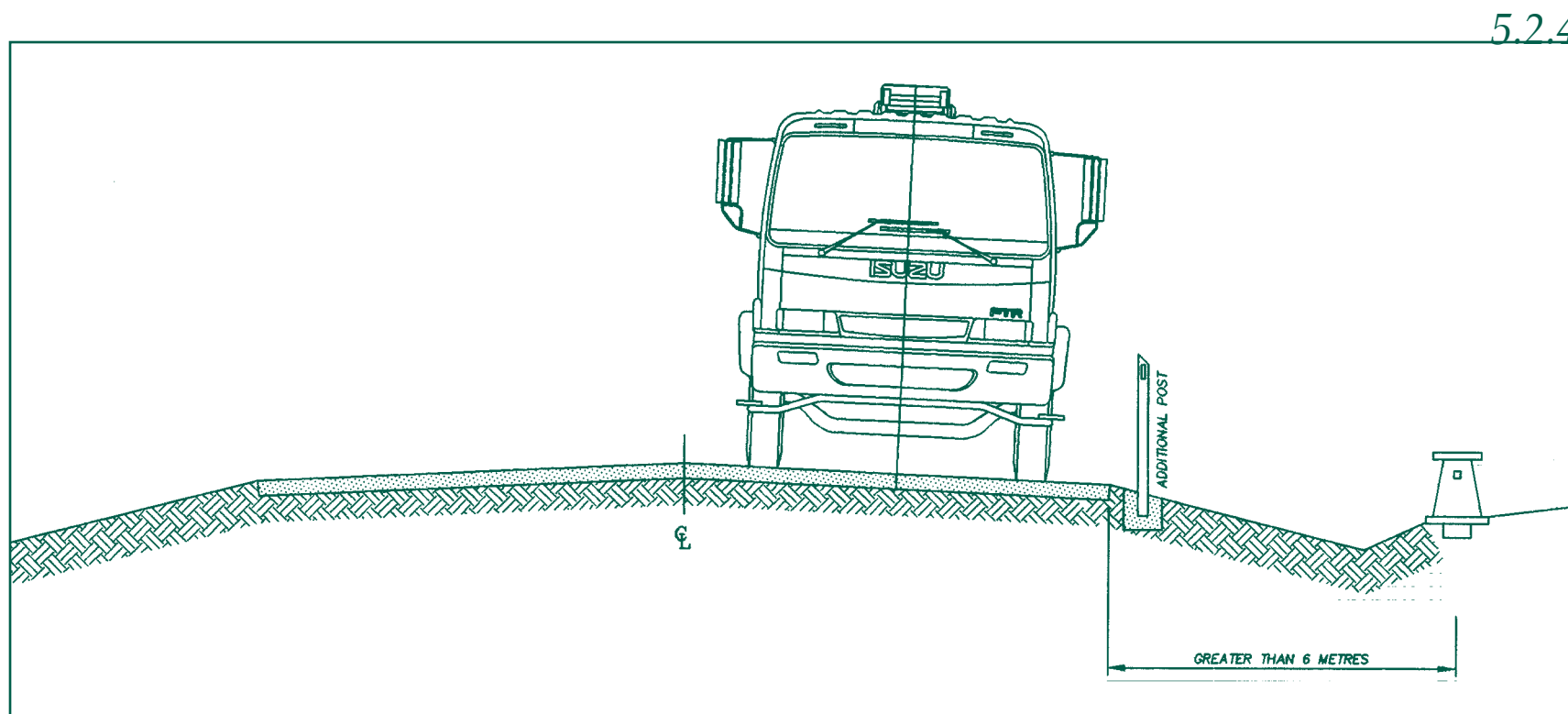

5.2.5 Areas where hydrant is concealed

When an above ground hydrant is installed in any area more than three metres from the normally maintained road edge and above the road level by more than three metres or below the road level by more than one metre, it is to be identified by a marker post (in accordance with 5.1.3) installed in such a position as to ensure that approaching fire appliances are directed to the location of the hydrant. This marker post is in addition to the standard identification requirements of the above ground hydrant cover, riser or body.

Explanatory notes:

The need to provide marker posts if the hydrant is above or below the road surface by the specified distances, provides for situations where the hydrant may be located in a drain, at the top of a cutting or remote to a particular location (hydrants provided in adjacent streets to serve freeways), thus being concealed to firefighting personnel.

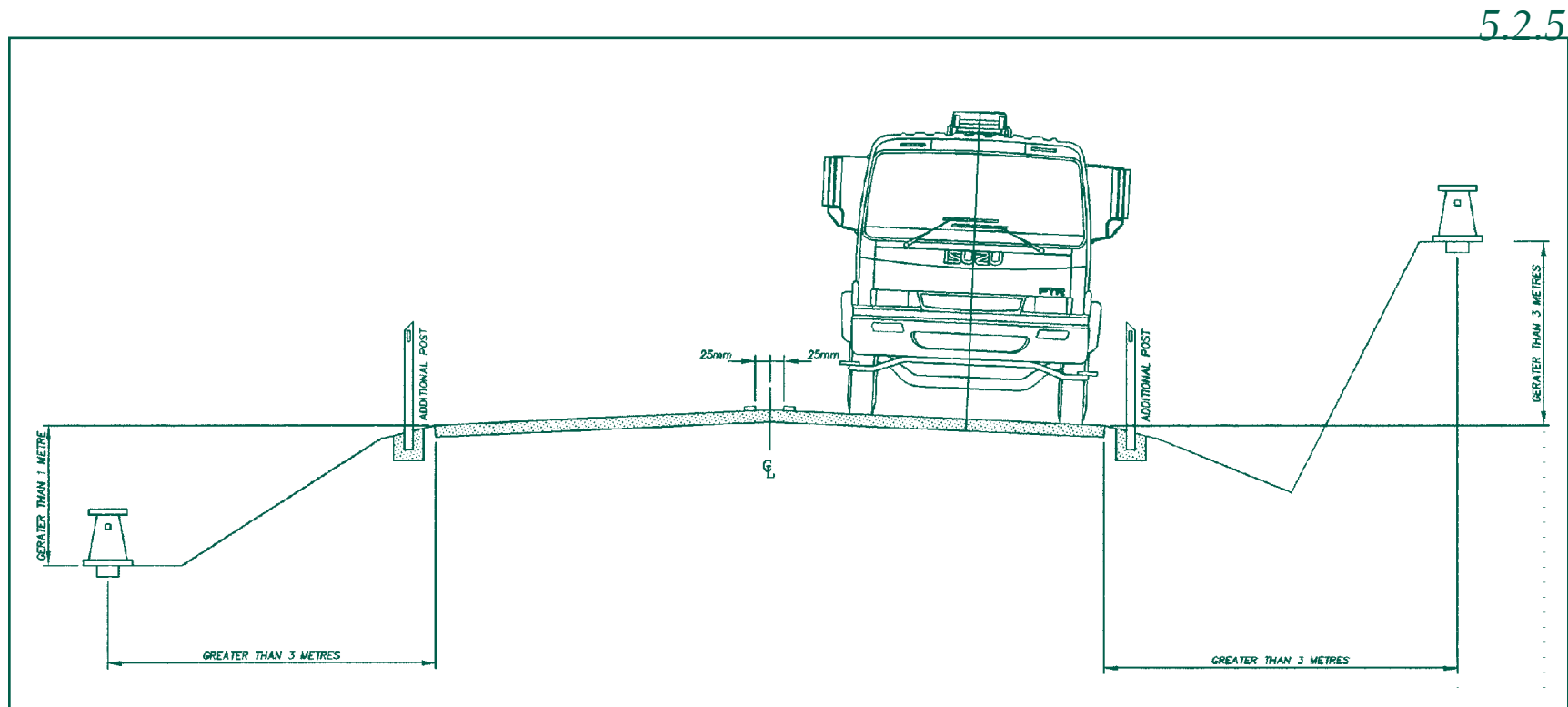

5.3 Below Ground Hydrants

5.3.1 Below ground hydrants identified by L type hydrant covers

L type hydrant covers installed to cover below ground hydrants are to have a red, non-reflective marking around the top of the hydrant, a blue reflective marker in accordance with 5.1.1(i) and an additional 25mm thick strip of blue reflective marking around the entire perimeter of the hydrant at a height of between 750mm and 1000mm above ground level. This additional marking strip is to be approximately 200mm below the blue reflective marker.

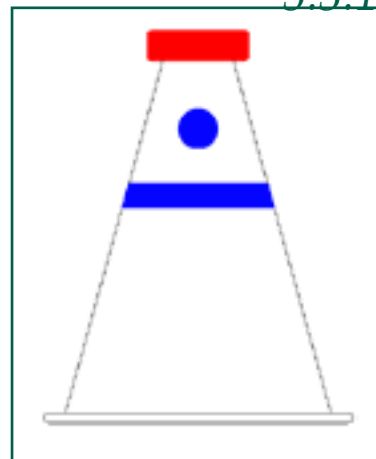

Explanatory notes:

It is the practice in some parts of the State to install L type hydrant covers above below ground hydrants.

The use of these covers to protect below ground hydrants presents a concern to the fire services, as the operating procedures for above ground and below ground hydrants differ. Currently, when a responding fire service is confronted with a normally identified L type hydrant cover, it is assumed that an above ground hydrant is installed, however this may not be the case. This has the potential to have serious consequences in an emergency.



5.3.2

5.3.2 Hydrant installed in roadways

Below ground hydrants, if installed in a sealed pavement roadway, are to be identified by a blue raised reflective road marker and the hydrant cover is to be coloured white or blue. If positioned in parking bays, they are also to be provided with a cleared area of at least 2 m, appropriately delineated or protected with parking barriers.

Explanatory notes:

Specifying blue raised reflective road markers for below ground hydrants installed in roadways provides for positive identification both during the day and at night in a position where it is impossible to provide a marker post. In the past, these hydrants were often identified by white painted diamonds which, although of limited success during daylight, have proven ineffective at a distance or at night. If authorities and municipalities wish to continue to use diamonds it must be in addition to reflective road markers.

For below ground hydrants installed in roadways within the parking strip, the delineation or protection of the hydrant is to reduce the potential for parked vehicles reducing access to the hydrant.

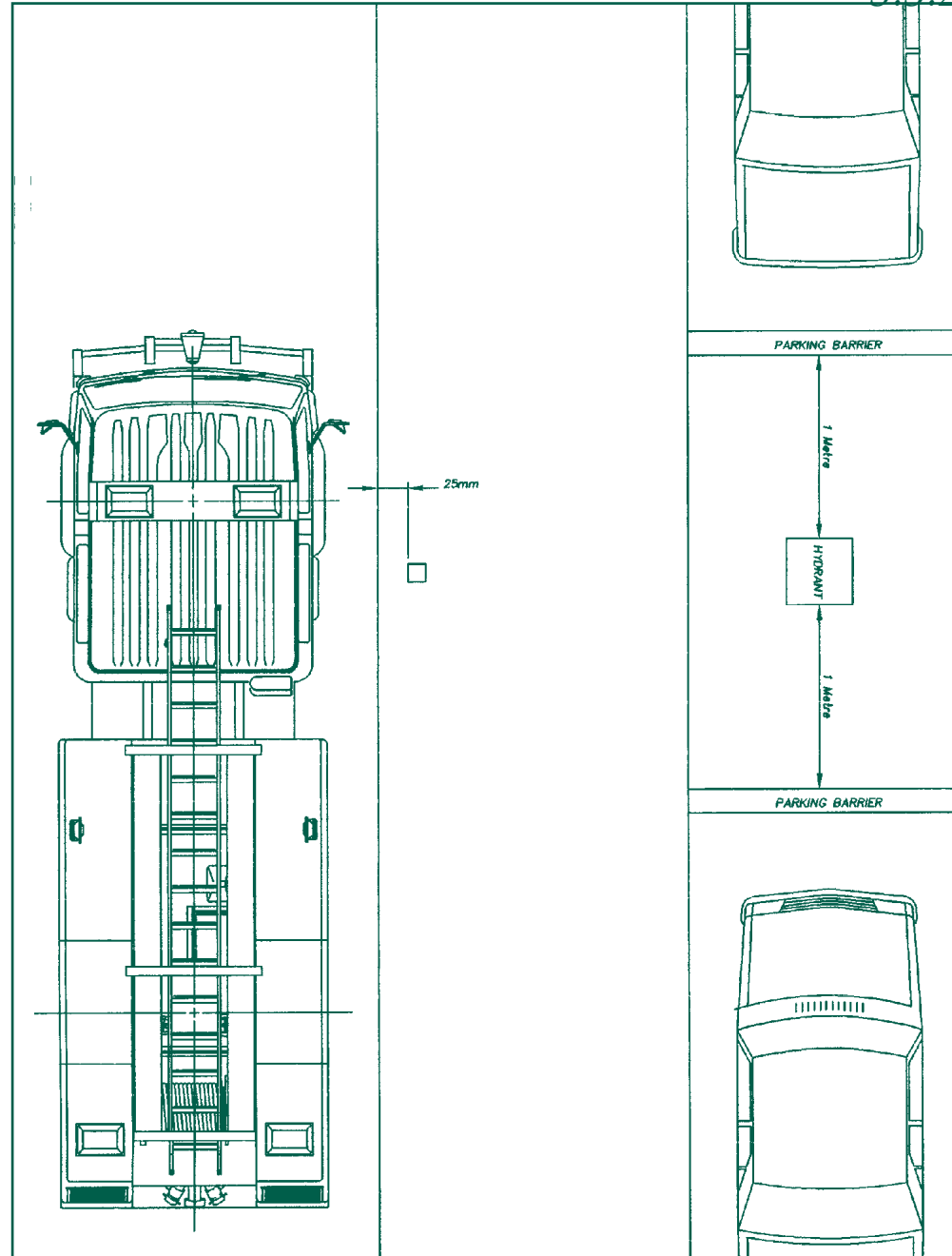

5.3.2

5

5.3.3 Areas with sealed pavement road, kerb and channelling

Below ground hydrants installed in areas with sealed pavement roads, kerb and channelling are to be identified:

- if installed in a nature strip they are to be identified by a marker post (in accordance with 5.1.3) and a blue raised reflective road marker; or
- if installed in a footpath they are to be identified by a white or blue access cover, a blue raised reflective road marker and vertical surface hydrant indicators (see 5.1.4) only where it is not possible to provide a marker post in accordance with 5.1.3.

Advisory note: The provision of painted (either white or blue) markings on the kerb between the blue raised reflective road marker and the hydrant is not an appropriate primary identification method. The use of these markings, in the colours white or blue are to be in addition to the above requirements and not as a substitute.

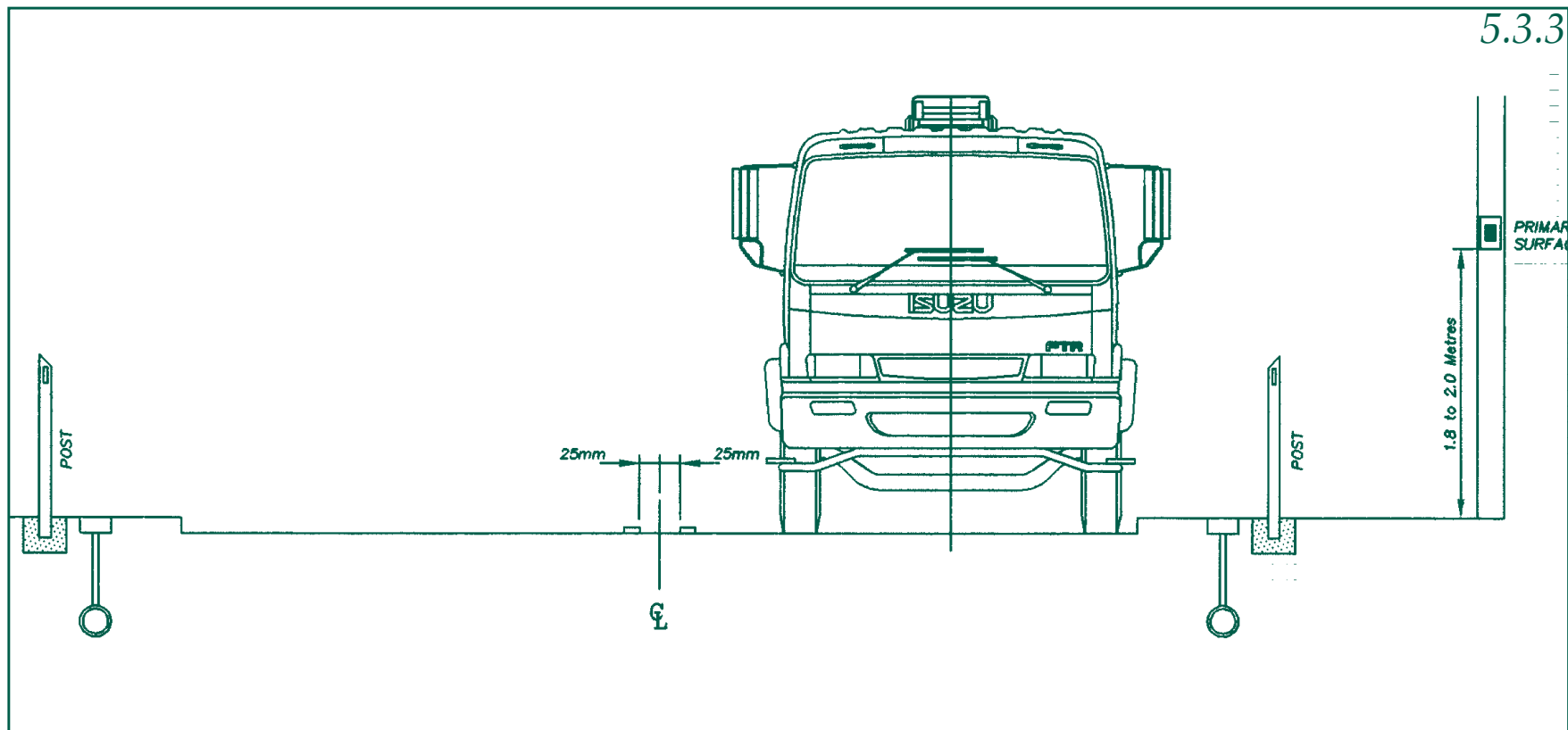

Explanatory notes:

This method of identifying the position of below ground hydrants has been used successfully for many years. The use of blue raised reflective road markers only provides for identification at a distance, however they do not provide more specific location identification and this can lead to delays in locating hydrants if covered or buried. Coloured access covers in footpaths provide a similar performance level in situations where it is unlikely that the hydrant could be covered and where the installation of marker posts is not possible due to the type of building abutting the footpath (ie: glass shopfront).

Vertical surface hydrant indicators provide an effective means of identification in areas where the use of marker posts is an impractical option. Such situations where their use may be required is in shopping malls and large paved open areas. The advantage of the vertical surface hydrant indicators is the variety of surfaces upon which they can be affixed. These indicators can be affixed to glass shopfronts, power poles or bins in appropriate areas to provide adequate identification of the hydrant.

The use of painted markings on the kerb between a raised reflective road marker and the hydrant should not be used as a primary identification system but as an additional identification.



5.3.4 Areas with sealed pavement road but no kerb and channelling

Below ground hydrants installed in areas with sealed pavement roads but no kerb and channelling are to be identified by:

- in areas with urban development - a blue raised reflective road marker and marker post (in accordance with 5.1.3); and
- in rural areas - a marker post (in accordance with 5.1.3) installed in such a position as to ensure that approaching fire appliances are directed to the hydrant.

Explanatory notes:

Again, the purpose of specifying blue raised reflective road markers for urban areas is to promote consistency. It is also likely that these urbanised areas will experience the same type of obstacles as areas with curb and channelling. The purpose of a marker post is to positively identify the hydrant location between the road and property. In rural areas the need for road markers is reduced, however, it is important that marker posts are appropriately marked and positioned to provide for efficient location.

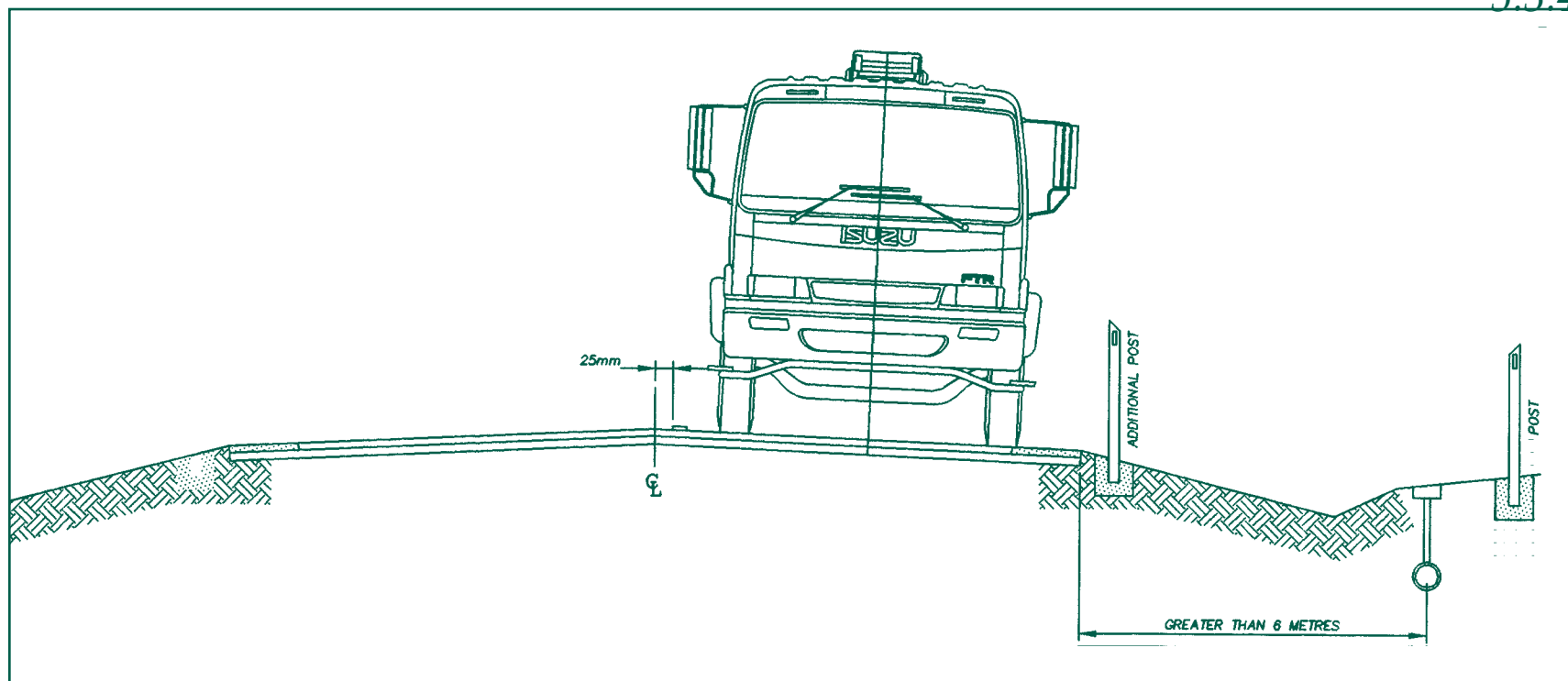

5.3.5 Areas with unsealed roads

Below ground hydrants installed in areas without sealed pavement roads are to be identified by a marker post (in accordance with 5.1.3) and if more than six metres from the normally maintained road edge, by an additional marker post (in accordance with 5.1.3) in such a position as to ensure that approaching fire appliances are directed to the location of the hydrant.

Explanatory notes:

The most appropriate and proven method in this situation is the use of marker posts. The requirement for an additional marker post in situations where the hydrant is more than six metres from the road is to ensure that a marker post installed adjacent to the hydrant is not missed, especially at night. It may also be that these installations are in rural areas where there are fewer hydrants or where they are provided for special risks only.

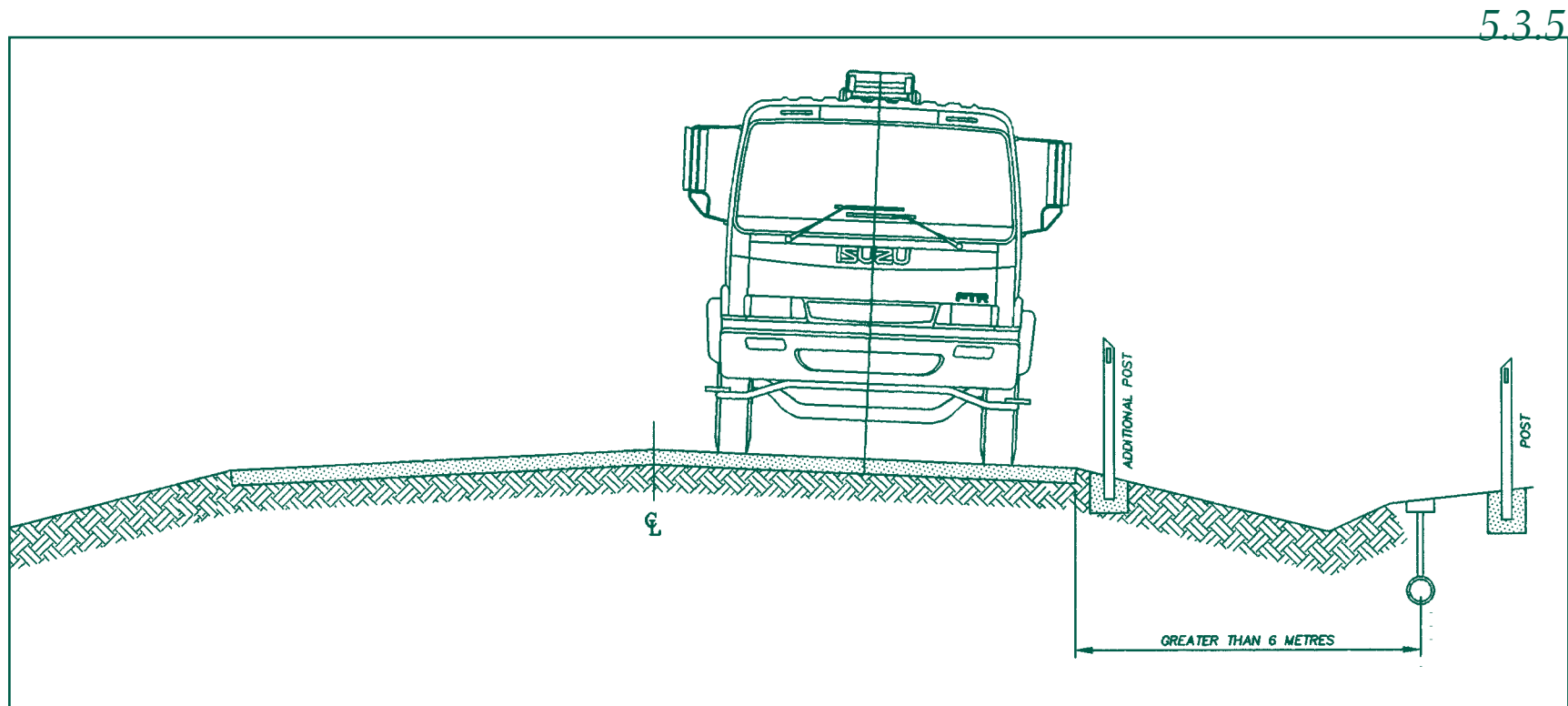

5.3.6 Areas where hydrant may be concealed

Below ground hydrants, when installed in any area more than three metres from the normally maintained road edge and above the road level by more than three metres or below the road level by more than one metre, are to be identified by a marker post (in accordance with 5.1.3) adjacent to the hydrant and an additional marker post (in accordance with 5.1.3) installed so as to ensure that approaching fire appliances are directed to the location of the hydrant.

Explanatory notes:

As with above ground hydrants, the need to provide marker posts if the hydrants are above or below the road surface by the specified distances provides for situations where the hydrant may be located in a drain, at the top of a cutting or remote to a particular location (hydrants provided in adjacent streets to serve freeways), thus being concealed to firefighting personnel.

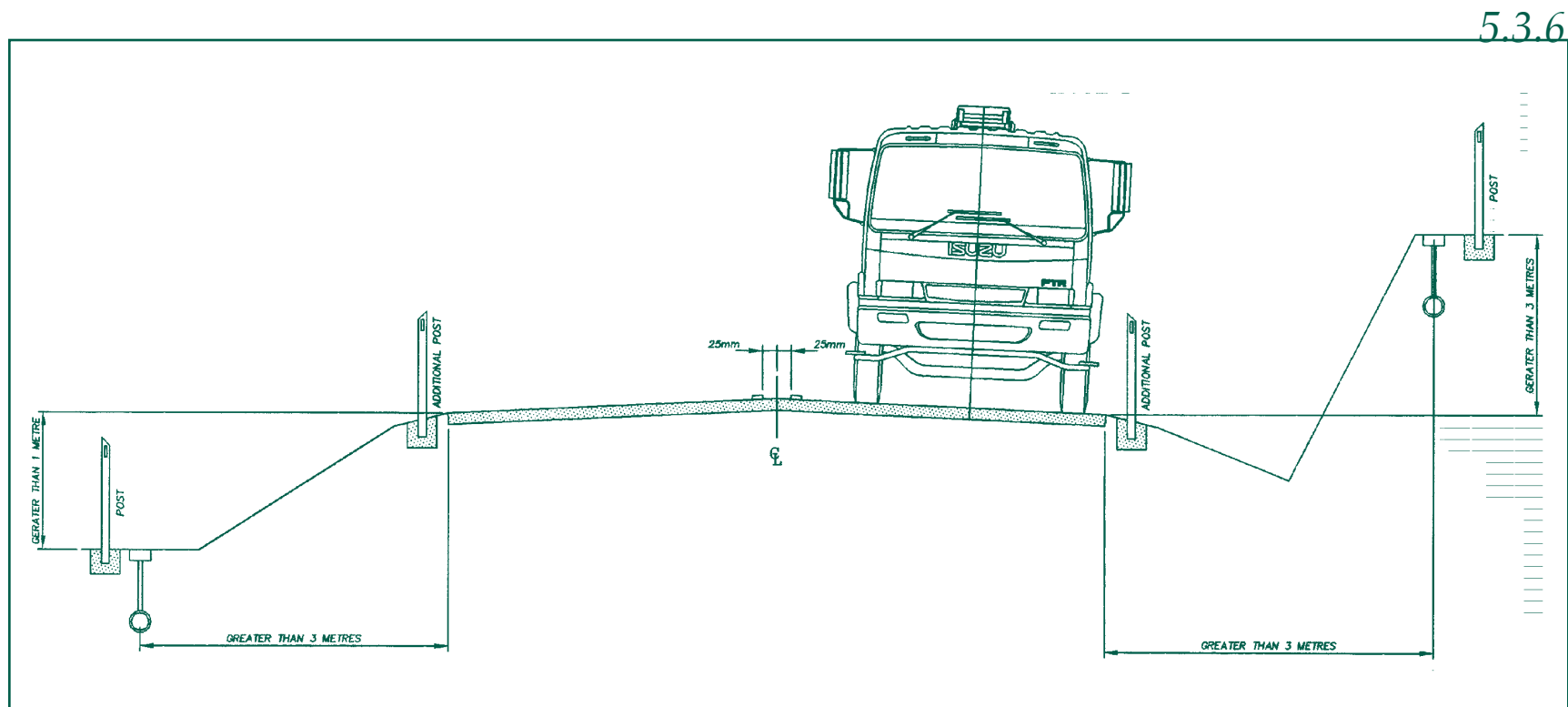

6.0 Maintenance

Hydrant identification systems are only effective while the performance criteria for identification continues to be met. All identification systems require regular maintenance to ensure their effectiveness.

All authorities responsible for the maintenance of hydrants should implement a program that will ensure:

- all hydrants are inspected on a regular basis;
- all aspects of the identification system are maintained in a condition that will ensure that the performance criteria outlined in Section 4.0 of these guidelines is met, (eg: posts cleared of obstructions, covers and hydrants painted where appropriate, reflective marker provided, etc).

Programs involving the community (nearby property owners) in the immediate vicinity of hydrants are an excellent way of reducing the frequency of inspections. Educating people to ensure the identification system remains visible and the hydrant accessible can reduce the need to undertake frequent inspections. Also, encouraging nearby property owners to contact the responsible authority when a problem occurs can influence the frequency of inspections.



Appendix A

Application Requirements For Hydrant Identification Variation

Applicant Details

- Applicants name
- Contact number
- Company
- Postal address

Information Regarding General Area of the Site

- Type of property in question
- Address of property
- Layout of property
- Responsible municipality
- Responsible water Authority
- Responsible fire service

Information Regarding Hydrant Identification

- Description of the building
- Surrounding environment
- Reasons why alternative hydrant identification required
- Description of the alternative hydrant identification system proposed

In addition to this, site plans and diagrams must be provided where possible.

Diagrams and plans of the alternative hydrant identification system must be provided in all cases.





CFA Community Safety Manager or CFA Community Safety Directorate,
8 Lakeside Drive, Burwood East (PO Box 701, Mt Waverley, 3149)
(03) 9262 8444.

MFB Zone Command or MFB Fire Safety Department,
433 Smith Street, Fitzroy North
(03) 9420 3874.

Department of Sustainability and Environment District Fire Management Officer
or Department of Sustainability and Environment Fire Management,
6/240 Victoria Parade, East Melbourne
(03) 9412 4777.

Authorised by the Victorian Government