



Caravan Park **FIRE SAFETY**

PUBLISHED MAY 2012





Please select an option below:

Foreword

Introduction

Definitions

Background

Key stakeholder responsibilities

Guideline structure

Application of the guideline

Alternative solution process

Objectives

Performance Measures

Prescriptive Provisions

Other guidance information

Checklist

References

Published May 2012



PRINT FRIENDLY VERSION



Foreword by the Chief Officers

Caravan parks are an iconic part of the Australian landscape and have become major providers of short- and long-term accommodation. Many parks provide a variety of self-contained cabins, powered *sites* for tourist caravans and tent *sites* for camping enthusiasts. Many also provide an affordable low-cost holiday-home alternative. Others provide residential villages for permanent living, that have a strong sense of community. The Victorian Fire Services recognise this wide range and diversity of caravan parks within the state.





Foreword by the Chief Officers



Euan Ferguson AFSM
CFA Chief Officer



Shane Wright AFSM
MFB Chief Officer

Fire safety risks and resources in caravan parks can vary dramatically across the state. The guideline aims to improve safety in all caravan parks, whether they provide short-term tourist van *sites* or more permanent holiday-home accommodation. This guideline aims to reduce the likelihood and consequence of fire within caravan parks to create a safer caravan park community.

Accordingly, this edition of the guideline responds to an ongoing need within the caravan park community to access a flexible and reasonable fire safety reference document.

The performance-style structure of the guideline continues on from the 2006 version, providing users with

the flexibility required to make *site*-specific fire safety improvements for their park. The guideline includes additional guidance information on topics such as maintenance of fire safety systems.

Using a consistent framework to identify the risks allows the guideline to be adapted to both new and existing caravan parks. It recognises that a solution for one caravan park may not suit another and provides stakeholders the opportunity to tailor a fire safety solution to suit their individual conditions.

It is important that all those with responsibilities in owning, managing and operating caravan parks – large or small – are fully aware of, and understand, their responsibilities and

obligations to ensure fire safety within caravan parks.

Fire safety not only makes good sense from a community safety point of view, it is also a good risk-management business decision. As the Victorian Fire Services, we invite key stakeholders to consider the alternatives offered by this guideline and work together to improve and maintain a satisfactory level of fire safety within new and existing caravan parks.

The success of this guideline is dependent on the support and cooperation of the Victorian Fire Services, caravan park owners and local councils.



Introduction

This guideline has been developed by the Victorian Fire Services (CFA and MFB) to provide a uniform set of technical provisions for the design and construction of caravan parks throughout Victoria. The guideline provides flexibility for *site*-specific variations due to geographical conditions or individual *site* constraints.

These provisions will enable the achievement of consistent, minimum and necessary provisions for fire safety and emergency management within caravan parks.

These provisions have been developed so that the requirements generate greater net benefits to society than the costs. The competitive effects of the requirements have been considered and the provisions are no more restrictive than necessary in the public interest.

This guideline can be applied to both existing and proposed caravan parks and can be used as a reference tool in relation to fire safety for:

- caravan park owners and occupants
- local government
- designers
- CFA and MFB personnel.





Introduction

To ensure a consistent approach is applied state-wide, regardless of the *site*, the guideline requires the following six objectives to be met:



01 PROVISION & MAINTENANCE OF FIRE SERVICE ACCESS



02 PREVENTION OF FIRE SPREAD



03 PROVISION & MAINTENANCE OF FIREFIGHTING EQUIPMENT

04 IDENTIFICATION & MANAGEMENT OF FIRE HAZARDS



05 DEVELOPMENT & IMPLEMENTATION OF EMERGENCY MANAGEMENT PLANS



06 COMPLIANCE WITH LEGISLATIVE REQUIREMENTS





Introduction



About the objectives

The user may demonstrate that they have satisfied these objectives by meeting the performance measures, prescriptive provisions or a combination of both. This approach gives the guideline a degree of flexibility that was not previously available, and enables the objectives to be met regardless of the situation, be it an existing or proposed caravan park.

Whilst the performance measures allow for development of *site-specific* fire safety provisions, their application relies upon the user demonstrating a considered approach based on risk-management principles established by the Australian and New Zealand Standard for risk management (AS/NZS 4360).

Appropriate application of this guideline requires consultation with Victorian Fire Services and other authorities, such as Energy Safe Victoria for the requirements of gas and electrical safety.

Combined with a suitable awareness of fire safety matters, this will facilitate compliance with existing legislative responsibilities and Victorian Fire Services requirements in relation to caravan park fire safety.



Definitions

The Act

Appropriate

Caravan park

Caravan/Movable dwelling/Tent

CFA

Degree necessary

Department of Planning and Community Development (DPCD)

Fire brigade operations

The Act

Residential Tenancies Act 1997.

Appropriate

Will perform as required relevant to the specific issue to achieve the desired outcome.

Caravan park

As defined by the *Residential Tenancies Act 1997*: "An area of land on which movable dwellings are situated for occupation on payment of consideration, whether or not immovable dwellings are also situated there."

This guideline applies to caravan parks only. Residential villages, retirement villages or the like are referred to the Victorian Fire Services separately in accordance with Sections 52 or 55 of the *Planning and Environment Act 1987* and accordingly, different fire safety requirements apply.

Caravan/Movable dwelling/Tent

As defined by the *Residential Tenancies Act 1997*: "A movable dwelling; or an immovable dwelling situated in a caravan park." This includes an unregistered movable dwelling (UMD). These may also be referred to as transportable structures.

Fire services staff

MFESB or MFB

The Regulations

Site

Structure

Suitably trafficable

Unobstructed

Qualitative

Quantitative argument

Victorian Fire Services



Definitions

Fire services staff

A CFA or MFB employee representing the applicable fire service on fire safety matters.

MFESB or MFB

Metropolitan Fire and Emergency Services Board, also known as the Metropolitan Fire Brigade. The relevant fire authority for the purposes of the *Residential Tenancies (Caravan Parks and Movable Dwellings Registration and Standards) Regulations 2010* within the metropolitan area.

The Regulations

Residential Tenancies (Caravan Parks and Movable Dwellings Registration and Standards) Regulations 2010.

Site

Any place within the perimeter of the caravan park including those occupied by *structures*.

Structure

Includes a caravan, movable dwelling, unmovable dwelling, tent or an ancillary/service building.

Note: For firefighter access and fire separation purposes, tents need only be separated by rented site rather than individually within a single rented site.

Fire services staff

MFESB or MFB

The Regulations

Site

Structure

Suitably trafficable

Unobstructed

Qualitative

Quantitative argument

Victorian Fire Services

The Act

Appropriate

Caravan park

Caravan/Movable dwelling/Tent

CFA

Degree necessary

Department of Planning and Community Development (DPCD)

Fire brigade operations



Definitions

- The Act
- Appropriate
- Caravan park
- Caravan/Movable dwelling/Tent
- CFA
- Degree necessary
- Department of Planning and Community Development (DPCD)
- Fire brigade operations

Suitably trafficable

Paved, sealed or hardened surface that is relatively even and continuous for pedestrian access.

This may include concrete, bitumen, grass or gravel, etc. but excludes garden beds or other inappropriate surfaces for people to walk on.

Unobstructed

Clear and without any object that reduces a required width including, but not limited to: hot water service, building fittings and fixtures, fences, garden beds, pot plants, sheds, storage of materials or equipment.

Qualitative

An argument based on comparative reasoning (i.e. expert judgement or opinion).

Quantitative argument

An argument based on numerical analysis (i.e. design computations or data).

Victorian Fire Services

Metropolitan Fire and Emergency Services Board and the Country Fire Authority.

- Fire services staff
- MFESB or MFB
- The Regulations
- Site
- Structure

Suitably trafficable

Unobstructed

Qualitative

Quantitative argument

Victorian Fire Services



Background

Within the state of Victoria, the construction, *site* layout and facilities within caravan parks are regulated by the *Residential Tenancies (Caravan Parks and Movable Dwellings Registration and Standards) Regulations 2010* ("The Regulations").

These regulations are made by the *Residential Tenancies Act 1997* ("The Act"). Fire safety is addressed by the regulations as detailed in Table 1.

Regulation number	Focus
■ Regulations 20 and 21	Fire prevention and safety
■ Regulations 22, 23 and 24	Emergency management plan, preventative measures and emergency procedures
■ Regulations 35	Smoke alarms for <i>movable dwellings</i>
■ Regulations 40, 43, 44, 45 and 46	Maintenance

Table 1 – Regulatory Requirements



Background

The Regulations

Regulations 20 and 21 require caravan park owners to consider fire separation, firefighter access, firefighting equipment. Regulations 22, 23 and 24 require caravan park owners to consider emergency management plans, preventive measures to be implemented and emergency procedures.

Owners should also be aware that the Regulations (Regulations 40, 43, 44, 45 and 46) require caravan park owners to conduct regular maintenance to ensure the fire safety elements are in good working order. Without suitable guidance this process can lead to inconsistencies.

Improving caravan park fire safety

An emerging trend towards developing caravan parks for almost exclusive long-term residential use and a desire to improve fire safety within existing caravan parks has contributed to a continuing need for a guideline that can be applied with confidence.

Furthermore, the Victorian Fire Services have an obligation to take all necessary steps for the prevention and suppression of fires and for the protection of life and property in case of fire. The prevention of fires clearly has a wider community benefit.

This updated guideline has been developed to attend to these issues within caravan parks with respect to current regulatory requirements.

Minimum fire safety requirements

The guideline is considered to be an appropriate method of establishing the minimum fire safety requirements for caravan parks. The Victorian Fire Services considers that all caravan parks should demonstrate a willingness to comply with this guideline.

The Victorian Fire Services have recognised the community need for a flexible and workable approach to achieving compliance. Therefore this guideline sets realistic objectives that are achievable through the use of a range of alternative designs. However, consultation with CFA and MFB Fire Safety Staff remains paramount.



Key stakeholder responsibilities

Fire safety within caravan parks is the joint responsibility of several stakeholders. Each of the following stakeholders has a key role in caravan park fire safety: caravan park owners, local council, Victorian Fire Services and other emergency services.

Caravan park owners

It is the responsibility of caravan park owners to ensure that the legislative requirements are met and the caravan park is operated in accordance with the registration issued by the local council. Regulation 10 of the Regulations states that a person must not operate a caravan park unless the caravan park is registered by the local council.

It is recommended that park owners review their caravan parks annually against this guideline, to ensure that the park is operating in the safest possible manner and identify any risks that need to be addressed. At the time of applying for registration or renewal of registration, the caravan

park owner should liaise with the relevant fire service to ensure that a relevant fire safety report has been completed prior to the application being made.

The owner is also responsible for notifying the local council of any proposed alterations to the caravan park. Any alterations must meet the statutory requirements of the regulations and the *Planning and Environment Act 1987*.

One of the regulated duties for caravan park owners is to ensure that firefighting equipment is maintained and in working order. They must also ensure that emergency services vehicles can access all areas of the park at all times. ▶



Guideline structure

The guideline is headed by the objectives. These objectives help to provide guidance on the level of community expectation by demonstrating compliance with the Performance Measures, by utilising the Prescriptive Provisions, or a combination of both. Figure 1 below depicts this structure.

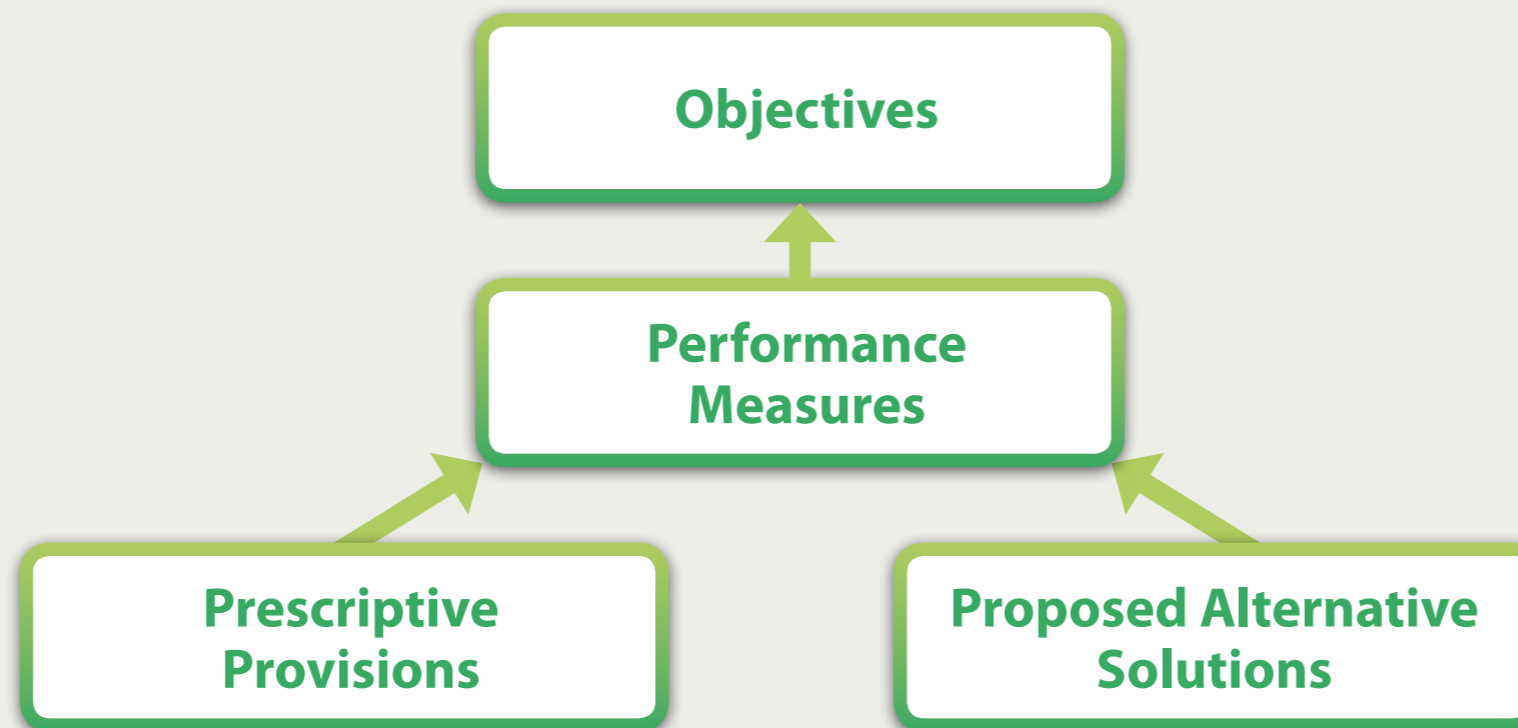

Figure 1 – Guideline structure



Guideline structure

Objectives (O)

Each objective represents an element of fire safety that needs to be addressed in a caravan park. All caravan parks should meet the objectives which are considered to reflect the minimum community and industry expectations and the needs of the Victorian Fire Services. Objectives explain the intent and help to aid interpretation of the performance measures.

Performance Measures (PM)

The Performance Measures state the level of performance that must be demonstrated by design proposals.

Compliance with the Performance Measures can be achieved by:

- complying with the prescriptive provisions;
- formulating an alternative which can show compliance with the Performance Measures or can be shown to be at least equivalent to the Prescriptive Provisions; or
- a combination of both.

Prescriptive Provisions (PP)

Compliance with the Prescriptive Provisions will automatically achieve compliance with the Performance Measures and avoid the need to prepare additional design information. The Prescriptive Provisions represent a community expectation minimum benchmark for meeting the objectives.

While this structure allows for the development of *site-specific* fire safety provisions, its application relies on the user to demonstrate a considered approach based on risk-management principles established by AS/NZS 4360. 



Guideline structure

Prescriptive Provisions (PP)

The guideline matrix below (Table 2) will help caravan park owners to determine which Performance Measures or Prescriptive Provisions are linked to which objectives.

Guideline matrix			
Objective	Performance Measure	Prescriptive Provision	
O1 PROVISION & MAINTENANCE OF FIRE SERVICE ACCESS	PM1 Firefighter access	PP1 Firefighter access & fire separation	
	PM2 Fire vehicle access	PP2 Fire vehicle access	
O2 PREVENTION OF FIRE SPREAD	PM3 Fire separation	PP1 Firefighter access & fire separation	
	PM4 Fire equipment	PP3 Occupant fire equipment	
O3 PROVISION & MAINTENANCE OF FIREFIGHTING EQUIPMENT	PM5 Fire authority equipment	PP4 Fire authority equipment	
	PM6 LP Gas	PP5 LP Gas	
O4 IDENTIFICATION & MANAGEMENT OF FIRE HAZARDS	PM7 Electrical safety	PP6 Electrical safety	
	PM8 Flammable liquids	PP7 Flammable liquids	
O5 DEVELOPMENT & IMPLEMENTATION OF EMERGENCY MANAGEMENT PLANS	PM9 Emergency Management Plan	PP8 Emergency management plan	

Table 2 – Guideline matrix



Application of the guideline

Applying the guideline to proposed and existing caravan parks

The Victorian Fire Services consider that this guideline must be implemented as follows.

New caravan parks

For new caravan park proposals, the guideline requirements are to be incorporated within the design during the planning stage prior to any relevant planning permit being issued.

During the planning permit process, a local council may seek advice from the relevant fire authority regarding any proposed caravan park. The local council may take the fire service's comments into consideration when making a decision on the registration of a new caravan park.

Caravan park owners must ensure that all information that is required to demonstrate compliance with this guideline is provided in the application to the local council. This will ensure that the Victorian Fire Services are provided with all relevant information and will reduce the likelihood of delays or the fire services not supporting the application.

New caravan parks should not be provided with registration by the local council unless they have demonstrated compliance with this guideline. ▶



Application of the guideline

Fire separation rationale – new and existing caravan parks

When developing a new caravan park, or developing new *sites* in an existing caravan park, caravan park owners should comply with the Prescriptive Provisions of this guideline (**PP1** and **PP2**). The provisions require a fire separation distance of 2 metres between and around dwellings to limit fire spread. They also require an unobstructed width of 1.2 metres between *structures* and a minimum height of 2.1 metres to allow a firefighter to move between *structures*, and to fight fires and conduct search and rescue activities as necessary. The Prescriptive Provisions

also require a caravan park owner to ensure that fire vehicles are able to access the park, ensuring that minimum standards for turning circles, gradients and dips in access roads are met.

Alternatively, a caravan park owner may choose to develop design solutions which meet the objective (**O1 – Provision and Maintenance of Access**) of the guideline by satisfying the Performance Measures (**PM1**, **PM2** and **PM3**). In developing this alternative design approach, advice should be sought from a registered fire safety engineer.

For full details, refer to the Alternative Solution Process section of this guideline. ▶



Application of the guideline

Established caravan parks

The performance-based approach of this guideline allows it to be applied to existing parks.

Caravan park owners should demonstrate a desire to incorporate the guideline requirements within the caravan park. While this may be achieved using the Prescriptive Provisions, the Victorian Fire Services recognise that complying with the Prescriptive Provisions may be difficult due to the existing infrastructure and financial viability issues.

Accordingly, application of this guideline to existing caravan parks should be sympathetic to these issues. Recommendations should focus on treating the identified risks, based on the principals of AS/NZS 4360.

This process may identify some significant works and may require the establishment of an implementation plan or schedule to complete the works over a reasonable time frame. The schedule should be mutually acceptable to the local council and the caravan park owner.

Caravan park owners can request the Victorian Fire Services to prepare a fire safety report to identify any fire safety risks and to ensure the application of the guideline to existing parks is reasonable and that any treatment options are consistent with the objectives of this guideline. 



Application of the guideline

Fire safety rationale – established caravan parks

It is the intention of the Regulations and this guideline to improve fire safety in existing caravan parks. However, it is recognised that in established parks, existing fire separation distances may not meet or be able to meet the 2-metre standard outlined in the Prescriptive Provisions.

If it is not feasible to increase the fire separation width on a *site* or throughout a caravan park as requested in the fire safety report, then the main consideration should be the overall fire safety of caravan park users. In these cases, additional safety measures may be appropriate (for example, additional hose reels or hydrants, external smoke detection and alarm systems, and/or improved

emergency management plans) and should be discussed with the relevant fire authority when the fire safety report is prepared.

However, it is expected that caravan park owners will undertake to improve fire separation distances over time – as *sites* are redeveloped or *movable dwellings* replaced. Where a new *movable dwelling* (either an unregistered *movable dwelling* (UMD) or a rigid annexe) is installed to an existing *site* in an established park, fire separation distances should be increased. This might be achieved through re-orientation of annexes, installation of narrower dwellings, or replacement of vans and annexes with UMDs. Separation distances must not be reduced when replacing dwellings in existing *sites*. ▶



Application of the guideline

Fire safety rationale – established caravan parks *continued*

When considering compliance with Regulation 21 (or any of the Fire Safety and Emergency Management Regulations 20–25 in Part 3 Division), local council should have regard to any report of the relevant fire authority (as per Regulation 26). Local council should ensure prior to registration that a mutually acceptable schedule of works is in place to improve fire safety within the caravan park.

Despite this, there may be cases where the relevant fire authority expresses serious concern over fire safety due to the fire separation distances in an

existing park. In these cases, caravan park owners may need to develop plans for improving the fire separation to meet the objectives of the guideline. Caravan park owners should agree with the council upon a schedule of works for completion over a mutually acceptable time frame. It is also important that the objective (**O1 – Provision and Maintenance of Access**) is not compromised where a UMD or rigid annexe is altered following installation, for example, through the addition of a carport, deck or verandah. The caravan park owner is responsible for ensuring that any such alterations do not affect fire safety compliance.

The Regulations do not require the local council to ensure compliance prior to registration. However, they provide the local council a framework for working with caravan park owners to ensure they are as safe as possible and that upgrade works are undertaken over time. ▶



Application of the guideline

Using the guideline

It is expected that all caravan parks are initially reviewed against the minimum Prescriptive Provisions. Where the Prescriptive Provisions cannot be met, alternative design proposals can be developed to meet the requirements of the Performance Measures.

There are three options available to determine compliance with the objectives. Figure 2 (following) represents the options available for achieving compliance.

Design proposals and layouts, along with emergency management plans supplied to the Victorian Fire Services for comment, should clearly identify the compliance option used for each fire safety element. 



Application of the guideline

Option 1: Comply with the Prescriptive Provisions

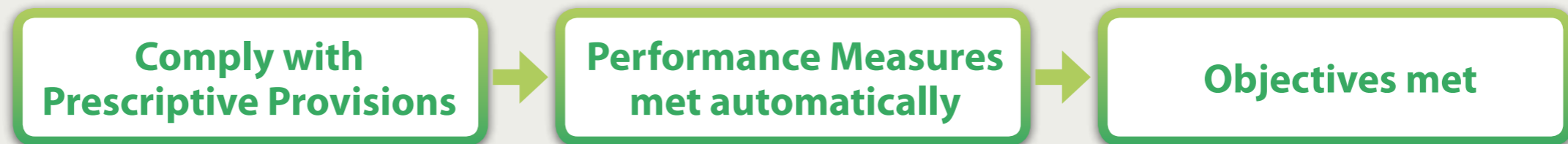

Option 2: Demonstrate compliance with the Performance Measures



Option 3: Comply with some aspects of the Prescriptive Provisions and demonstrate compliance with some aspects of the Performance Measures



Figure 2 – Compliance options



Application of the guideline

Complying with Prescriptive Provisions

The Prescriptive Provisions of the guideline offer an established solution for meeting the guideline objectives. Compliance with the Prescriptive Provisions does not require the preparation of alternative design proposals.

In order to comply with a Prescriptive Provision every aspect of the provision must be met. Discretion as to whether or not a Prescriptive Provision has been met will ultimately lie with Victorian Fire Services when undertaking a fire safety audit. Meetings or inspections with Fire Safety Staff are encouraged to ensure that design proposals meet the Prescriptive Provisions.

Demonstrating compliance with Performance Measures

Where alternative designs are proposed to meet the Performance Measures, alternative design proposals must be prepared with sufficient information to demonstrate compliance. Both *quantitative* and *qualitative* information may be utilised. Alternative design proposals must include supportive evidence that may be based on:

- comparison with the Prescriptive Provisions; or
- documentary evidence that the use of a material, form of construction or design meet the Performance Measures (i.e. test certificates indicating a material's fire hazard properties); or

- expert judgement in the form of a Fire Engineering Analysis prepared by a suitably qualified Fire Safety Engineer. Expert judgement must be conducted by a person who has the qualifications and experience to determine whether a design proposal complies with the Performance Measures.

Only a building practitioner who is registered as a Fire Safety Engineer should design a fire safety alternative solution. The alternative solution should encompass the fire safety performance requirements of the guideline. 



Application of the guideline

The use of expert judgement should only be utilised where the options provided by the guideline have been exhausted. If a caravan park owner uses an expert's judgement to analyse a design or an alternative design, it is strongly recommended that it be reviewed by an independent third party. The third party conducting any such review should be an independent person who can qualify their expertise.

The extent to which any assessment method is proposed to be used within the design of the fire safety alternative solution should be discussed and agreed upon by all stakeholders as part of the development of the proposed alternative solutions.

Alternative solutions to meet Performance Measures

The alternative solutions process is optional. It only needs to be done by those who do not wish to follow the Prescriptive Provisions. 

[Skip to "Objectives" !\[\]\(5361750c22c4e047a52f4eac1ec2d4cc_img.jpg\)](#)

Figure 3 – Alternative solution process



Alternative solution process

The alternative solutions process is for caravan park owners who elect to develop alternative designs to meet Performance Measures, instead of complying with Prescriptive Provisions.

It is expected that five general stages of a consultation process be followed (see figure 3, below). These stages will allow caravan park owners to effectively develop a fire safety solution to address the Performance Measures outlined in this guideline.

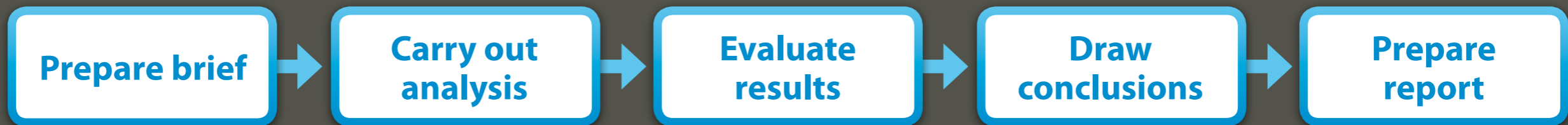

Figure 3 – Alternative solution process



Alternative solution process

Prepare a brief

The brief outlines the alternatives you are proposing and how you will develop an alternative solution to ensure it will satisfy all of the Performance Measures. This process may include discussions with consultants and stakeholders to ensure that analysis and evaluations are agreed to by all relevant parties.

Analysis

Using the brief, analyse the proposed alternative solutions. This may involve consultation with specialists to gather engineering calculations or statistical analysis, or comparison against other documentation such as the National Construction Code.

Evaluate results

Adjust the plan according to any recommendations resulting from the analysis.

Draw conclusions

Outline how your proposal complies with the Performance Measures.

Prepare report

Compile a formal report, including all details of the proposed alternative solution. This is what will be assessed by Victorian Fire Services and local council. ▶



Alternative solution process

Preparing the brief

The brief is an essential part of the alternative solution design process. It allows the broader community aspirations to be taken into account during the development and evaluation of alternative solutions, while at the same time ensuring that levels of safety accepted by the community are maintained.

The brief might only be a short document, particularly if the proposed alternative solution is only a simple departure from the Prescriptive Provisions. However, for large and/or complex projects, the brief could be substantial.

Ideally, the brief should be developed collaboratively by all the relevant stakeholders, but this may vary according to the particular circumstances of the project design.

Relevant stakeholders could include but should not be limited to:

- caravan park owner/manager
- fire safety consultant appointed by the park owner
- caravan park designers, including architects, service designers/consultants
- dangerous goods consultants
- relevant local council
- Victorian Fire Services (either CFA or MFB, depending on the area).



Alternative solution process

Preparing the brief *continued*

The brief should give clear direction for consultants and designers on the expectations of all stakeholders. This allows consultants and designers to effectively prepare any documentation that may be required. As the regulations and community expectations change over time, the level of documentation dealing with risks will change. Undertaking a briefing with consultants and ensuring that all authorities are represented will ensure their expectations can be met.

Consultation with Victorian Fire Services

Involving the Victorian Fire Services in the stakeholder consultation process will aid the development of a thorough/acceptable brief. Having this support from the Victorian Fire Services will increase the likelihood of approval for the alternative solution. This, in turn, will lead to the registration being granted in a timely manner by the local council.

If the Victorian Fire Services are not consulted during the briefing process, it is likely that the outcomes of any consultant's reports or future designs may not meet the objectives and expectations of Victorian Fire Services objectives and expectations. In these instances design team stakeholders will be informed that the Victorian Fire Services are unable to endorse the fire safety alternative solution final report. ▶



Alternative solution process

The process – understanding fire brigade intervention

When developing an alternative fire safety solution, it is important to understand what is involved in a fire brigade intervention. Caravan park owners need to understand the time it may take for a fire brigade to respond and what the fire brigade will do upon arrival. It is important that caravan park owners understand the effect that an alternative design has on the fire brigade intervention process, such as the need to use street hydrants to provide full coverage to the caravan park.

What is fire brigade intervention?

Fire brigade intervention encompasses all fire brigade activities, from the time of notification up to fire extinguishment and overhaul.

Figure 4 (following) provides a graphical interpretation of fire brigade intervention and *fire brigade operations* as defined by the Australasian Fire Authorities Council (AFAC).

Caravan park owners are not expected to carry out an assessment of fire brigade intervention. However, they must understand fire brigade intervention when designing alternative solutions. ▶



Alternative solution process: Fire brigade intervention

The Regulations specify that the caravan park owner is responsible for meeting the performance requirements, including ensuring that their park design provides reasonable opportunity for firefighting within the park.

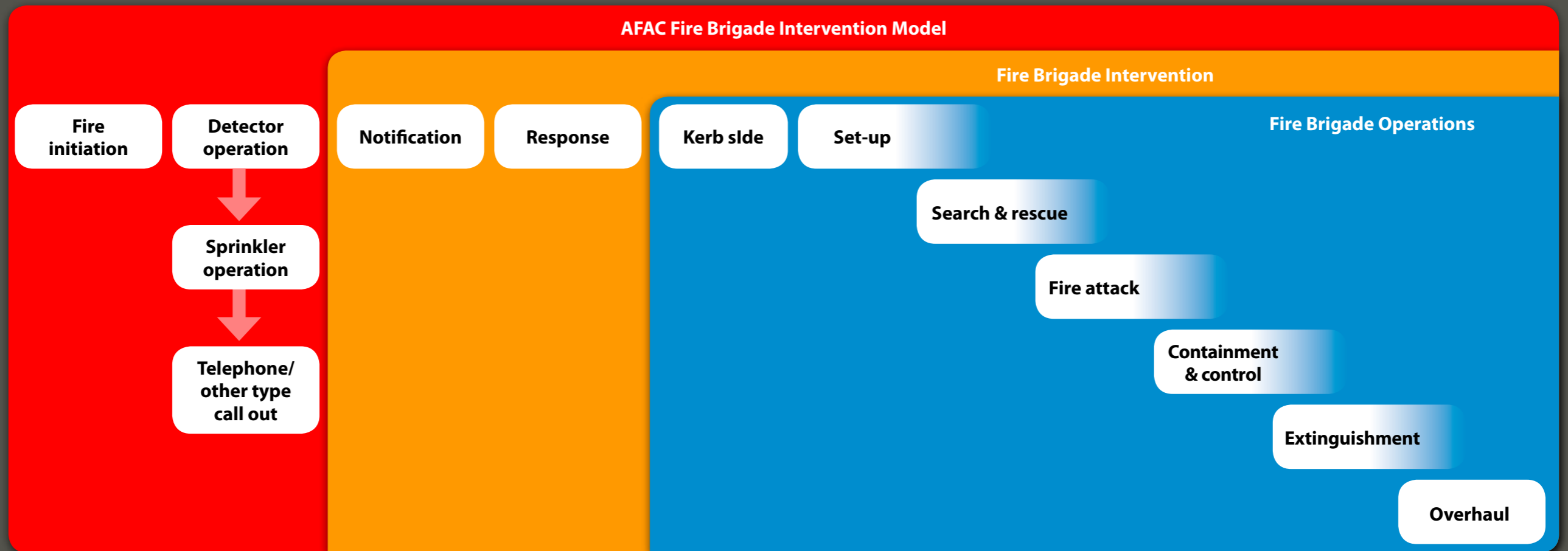

Figure 4 – Fire brigade intervention



Alternative solution process: Fire brigade intervention

Fire brigade intervention model

The Victorian Fire Services support the use of the AFAC Fire Brigade Intervention Model. The model is an engineering tool that can be utilised to address the fire performance requirements of the guideline where fire brigade intervention is a consideration. The tool can be utilised by caravan park owners and their consultants to determine the time required for the attending fire brigades to complete tasks commencing from fire notification through to fire control and extinguishment.

Caravan park owners should consult Victorian Fire Services to determine the extent of fire brigade intervention required.

Through meetings and/or inspections, Victorian Fire Services will ensure that proposed alternative solutions meet the Performance Measures and that they are mutually acceptable to park owners and fire services.

Using the model

Caravan park owners can use this model to understand the implications of fire brigade intervention and demonstrate compliance with **PM3**. Caravan park owners suggesting an alternative solution must consider the time required for fire brigade intervention. This time may greatly affect how many *structures* are affected by a spreading fire, as well as the potential for loss of life. In particular, caravan park owners who are relying on fire brigade response in their alternative solution must consider this aspect carefully. ▶



Alternative solution process

Assessment of fire brigade intervention

The final fire safety report should be a full assessment of fire brigade intervention. It is insufficient for the report to simply acknowledge the location of fire stations and indicate a 90 percentile kerbside arrival time. The final report should conclusively demonstrate that firefighters will be given a reasonable period of time to enter a caravan park/building to conduct occupant search and rescue activities.

Documenting the process

All stages of the alternative solution process should be documented. This includes the initial brief, analysis and evaluation, and any amendments decided upon to address deficiencies with the original proposed solution. These records will contribute to the final report, which is presented to Victorian Fire Services and the local council for the caravan park to be approved for registration. ▶



Alternative solution process

Who can provide professional advice?

There are a number of industry professionals who can provide advice on meeting the caravan park guidelines. These include architects, building designers, services designers and engineers.

With the Regulations referring to documents such as the National Construction Code it opens new and additional professionals to the design of caravan parks who traditionally may not have been involved, such as building surveyors and building inspectors.

As the caravan park industry changes and evolves and the community expectation of life safety changes, it will become increasingly important for caravan park owners and managers to have knowledge and understanding of all of the legislation and regulations that apply to caravan parks. Therefore it is important that park owners understand the type of consultants they can engage and the knowledge that these professionals can provide. ▶



Alternative solution process: Professional advice

In Victoria, a Registered Building Practitioner may be the best person to start with when seeking the services of a consultant. Utilising a Registered Building Practitioner will give caravan park owners some comfort that the person they are seeking advice from has been assessed and deemed competent in the field that they are working. Registered Building Practitioners are also required to carry insurance. The Building Commission can provide advice on practitioners, and caravan park owners can search for a particular field of expertise through the Building Commission website **buildingcommission.com.au**

However, there is no regulatory requirement to use consultants; caravan park owners can prepare information themselves, showing that the park meets the guideline.

Owners must ensure that any consultant they engage holds insurance, whether related to issues within this guideline, or for any other advice sought.

The Victorian Fire Services are not consultants. Whilst the fire services can provide advice regarding Performance Measures and Prescriptive Provisions, the fire services cannot design or formulate alternative solutions for park owners. ▶



Alternative solution process: Final report

Preparing the final report

When consulting Victorian Fire Services about the alternative solution, caravan park owners must prepare sufficient documentation to present to the fire services for review. Victorian Fire Services requires a minimum level of documentation in order to carry out an evaluation of the alternative solution. This documentation should be compiled throughout the alternative solution process, starting with the brief and include analysis, evaluation and conclusions.

Report structure

Consultant report

- Executive summary
- Scope of the report
- Details of the briefing. This section should contain the basic information of the briefing process and use the following section headings as appropriate:
 - » Relevant stakeholders
 - » Principal park characteristics
 - » Dominant occupant characteristics
 - » General objectives (contained within the caravan park guidelines)
 - » Hazards and preventative and protective measures available
 - » Method of analysis/justification
 - » Acceptance criteria and factors of safety
 - » Fire scenarios and parameters for alternative designs
 - » Potential fire scenarios
 - » Standard of construction, commission and management in use and maintenance.





Alternative solution process: Fire safety report

- Analysis should include:
 - » analysis of the strategy;
 - » any calculations; and
 - » any results obtained.
- Evaluation of results

This should be included if any engineering expert judgement has been used, along with its justification.
- Conclusions should include:
 - » a statement by the report writer that the proposal complies with the Performance Measures of the guideline;
- » any limitations on the proposal or design;
- » any construction requirements to ensure that the fire safety system is properly accomplished;
- » any commissioning requirements; and
- » any procedures or processes that are to be adhered to during the management and use of the caravan park.
- References
 - » Australian Standards, Industry Technical Documentation etc. ▶



Alternative solution process: Fire safety report

- Drawings and technical data, including:
 - » water authority test data confirming available water supply (this is particularly important for designs that propose the use of firefighting equipment);
 - » architectural drawings showing the park layout and location of any Victorian Fire Services;
 - » scale drawings showing hydrant locations and coverage from those hydrants, including measurements showing any shortfalls identified;
 - » location of emergency vehicle access points and accessibility to firefighting equipment; and
 - » hydraulic design calculations for any firefighting equipment to be used by the fire brigade, confirming the expected performance.
- Consultant Curriculum Vitae
- Any third party peer-review report. ▶



Objectives

These objectives meet minimum community expectations. If these six objectives are adequately addressed, the fire safety of the *site* will meet the requirements of Victorian Fire Services. Compliance with these objectives must be demonstrated by meeting the Performance Measures. This can be meeting the Prescriptive Provisions, proposing an alternative solution that meets the Performance Measures or a combination of both.



O1 Provision and maintenance of access

Adequate access must be provided and maintained within caravan parks to the *degree necessary* for:

- a. firefighters, between and around any *structure*;
and
- b. fire vehicles, including pumpers and tankers.

O2 Prevention of fire spread

Adequate separation distance must be provided and maintained between and around any *structure* to prevent fire spread so that:

- a. occupants can safely evacuate; and
- b. the potential for fire spread to multiple *structures* is reduced. ▶



Objectives



O3 Provision and maintenance of firefighting equipment

Appropriate firefighting equipment must be provided and maintained to enable:

- a. occupants to undertake an initial fire attack; and
- b. the fire service to fight the fire as necessary.



O4 Identification and management of fire hazards

Potential fire hazards must be identified, minimised and maintained safely.

Note: Compliance with legislative requirements must be achieved regardless of whether Performance Measures or Prescriptive Provisions are used.





Objectives



O5 Development and implementation of emergency management plans

Site-specific emergency management plans must be developed and maintained to reflect the assessed risk.



O6 Compliance with legislative requirements

The relevant legislative requirements, as amended from time to time, must be met.

Note: *Compliance with legislative requirements must be achieved regardless of whether Performance Measures or Prescriptive Provisions are used.*



Performance Measures

Demonstrating compliance either by using the Prescriptive Provisions or formulating an alternative solution with the following Performance Measures will ensure that the guideline Objectives are met.

PM1 Firefighter access



Access for firefighters must be provided and maintained to ensure that they are able to:

- travel externally and directly in pairs to the front and rear of a *structure* in full structural personal protective clothing (PPC), including breathing apparatus; and
- travel *unobstructed* on a *suitably trafficable* surface; and
- undertake firefighting activities as required.

PM2 Fire vehicle access



Access for fire vehicles must be provided and maintained to enable:

- access for firefighting vehicles as required; and
- firefighting operations to be conducted within any part of the caravan park from the fire appliance as necessary. ▶



Performance Measures

PM3 Fire separation



All *structures* must be sited and clearances maintained to ensure that the likelihood of fire spread between *structures* is reduced appropriate to:

- a. potential fire intensity;
- b. potential flame contact;
- c. potential radiation;
- d. the distance between *structures*;
- e. fire service intervention; and

All *structures* must be sited to ensure that occupants can safely evacuate to a designated assembly area in an emergency.

PM4 Fire equipment



Fire equipment must be provided and maintained appropriate to the identified risks.

Fire equipment must be provided and maintained:

- a. in locations accessible to all caravan park occupants; and
- b. with appropriate signage. ▶



Performance Measures

PM5 Fire authority equipment



A water supply must be provided and maintained for use by the relevant fire service appropriate to:

- a. the likely fire services response; and
- b. the identified risks and hazards.

Fire hydrants must be provided and maintained where reticulated water supply is available:

- a. at operable locations acceptable to the relevant fire service; and
- b. with appropriate signage or markers.

If reticulated water supply is unavailable, static water supply for fire service use must be provided and maintained:

- a. with quantities appropriate to the identified risks and hazards;
- b. with fittings appropriate to the relevant fire service;
- c. in operable locations acceptable to the relevant fire services; and
- d. with appropriate signage and markers.

PM6 LP Gas



LP Gas storage within caravan parks must be monitored and maintained appropriate to:

- a. storage size;
- b. storage location;
- c. storage type; and
- d. use. ▶



Performance Measures

PM7 Electrical safety



Electrical safety must be implemented and maintained within all caravan parks and *structures*.

PM8 Flammable liquids



Flammable liquids within caravan parks must be monitored and maintained appropriate to:

- storage size;
- storage location;
- storage type; and
- use.

PM9 Emergency management plan



An emergency management plan must be developed appropriate to:

- caravan park size and characteristics;
- number of staff and occupants;
- available emergency services;
- identified fire risks and hazards (including bushfire); and
- available egress from the *site*.

The emergency management plan must be displayed in an area that is easily accessible by the fire services. ▶



Prescriptive Provisions

FIREFIGHTER ACCESS



FIRE SEPARATION

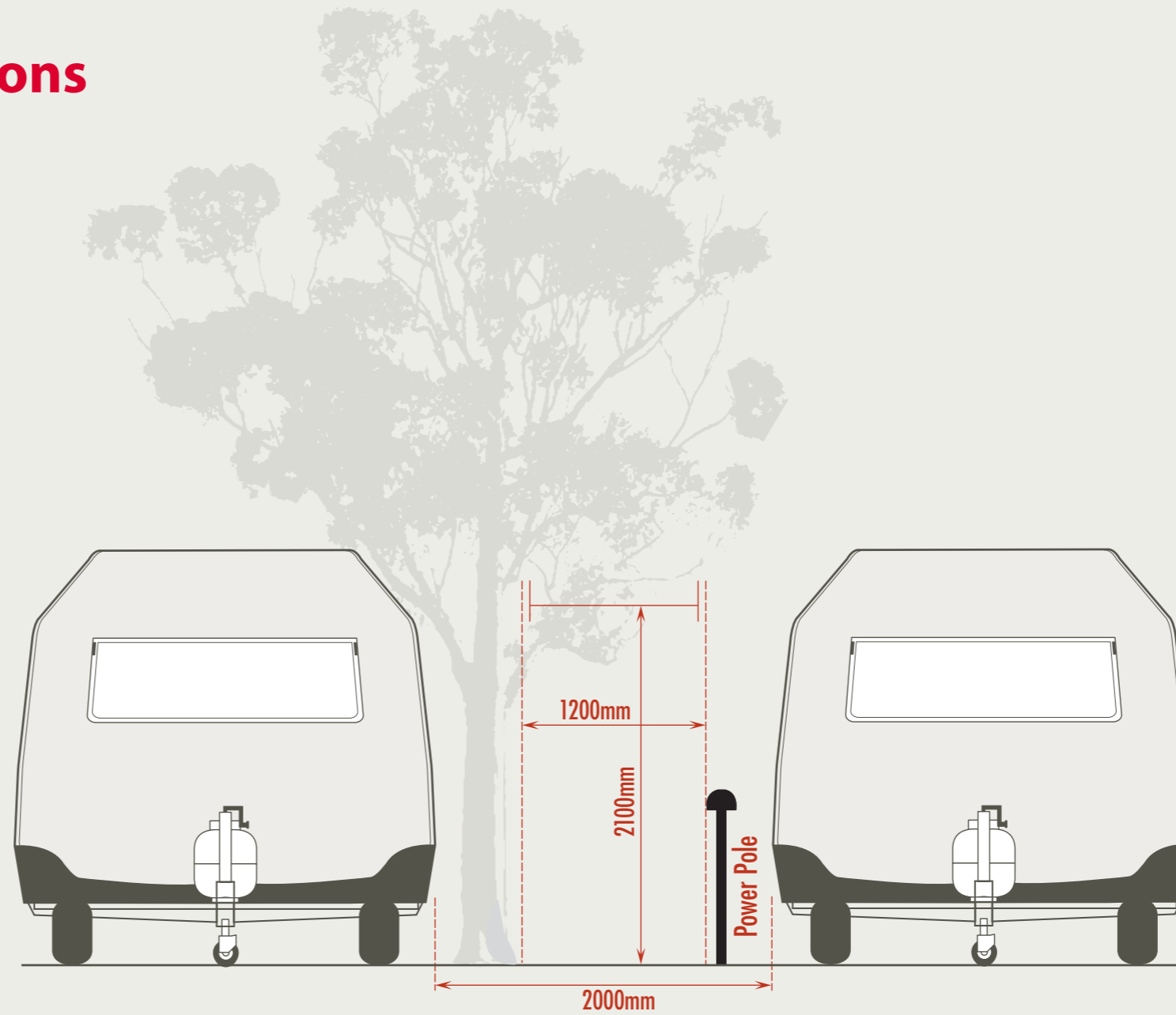

Figure 6 – Caravan to caravan fire separation





Prescriptive Provisions

FIREFIGHTER ACCESS



FIRE SEPARATION

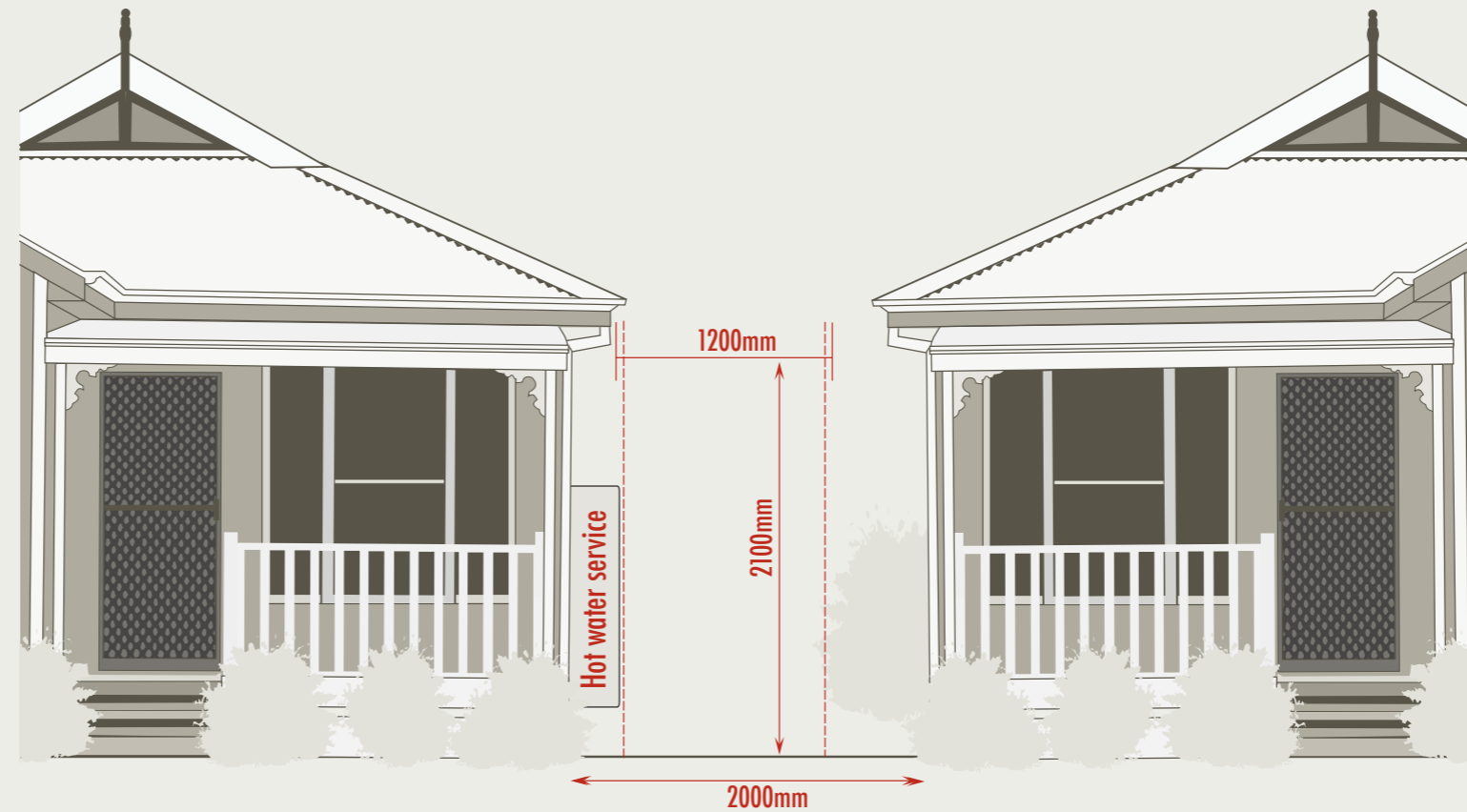

Figure 7 – Movable Dwelling to Movable Dwelling





Prescriptive Provisions

FIREFIGHTER ACCESS



FIRE SEPARATION

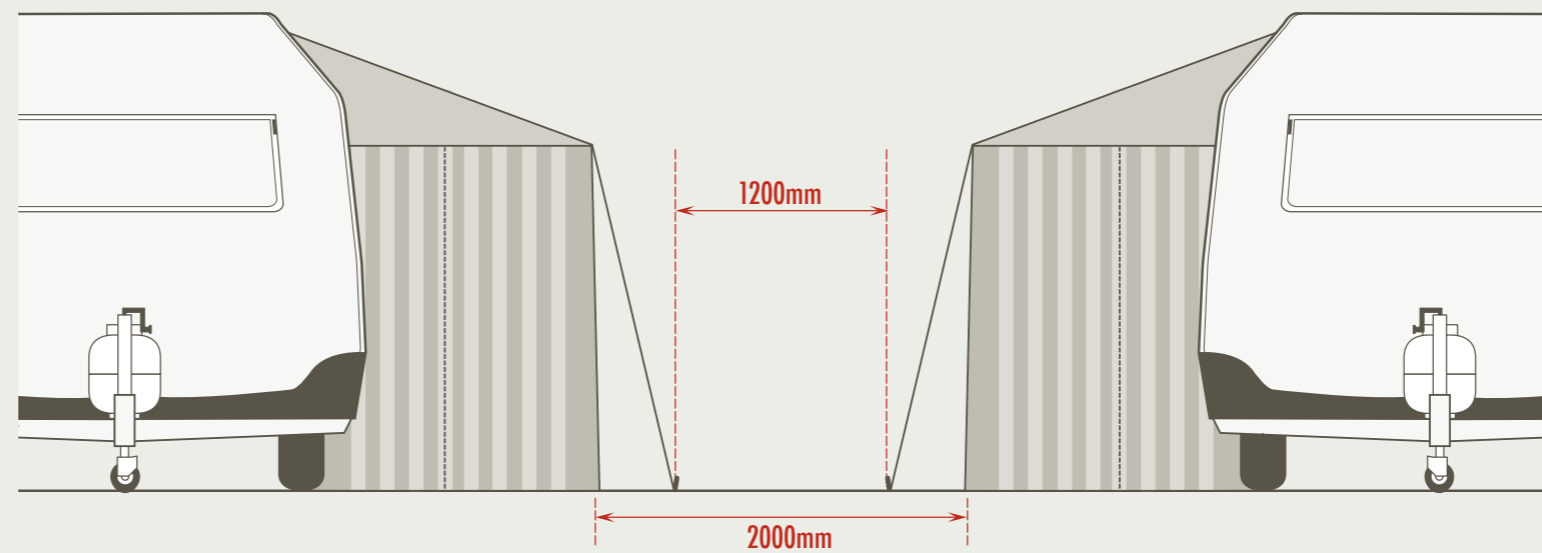

Figure 8 – Caravan anexe to caravan anexe fire separation



Prescriptive Provisions

FIREFIGHTER ACCESS



FIRE SEPARATION

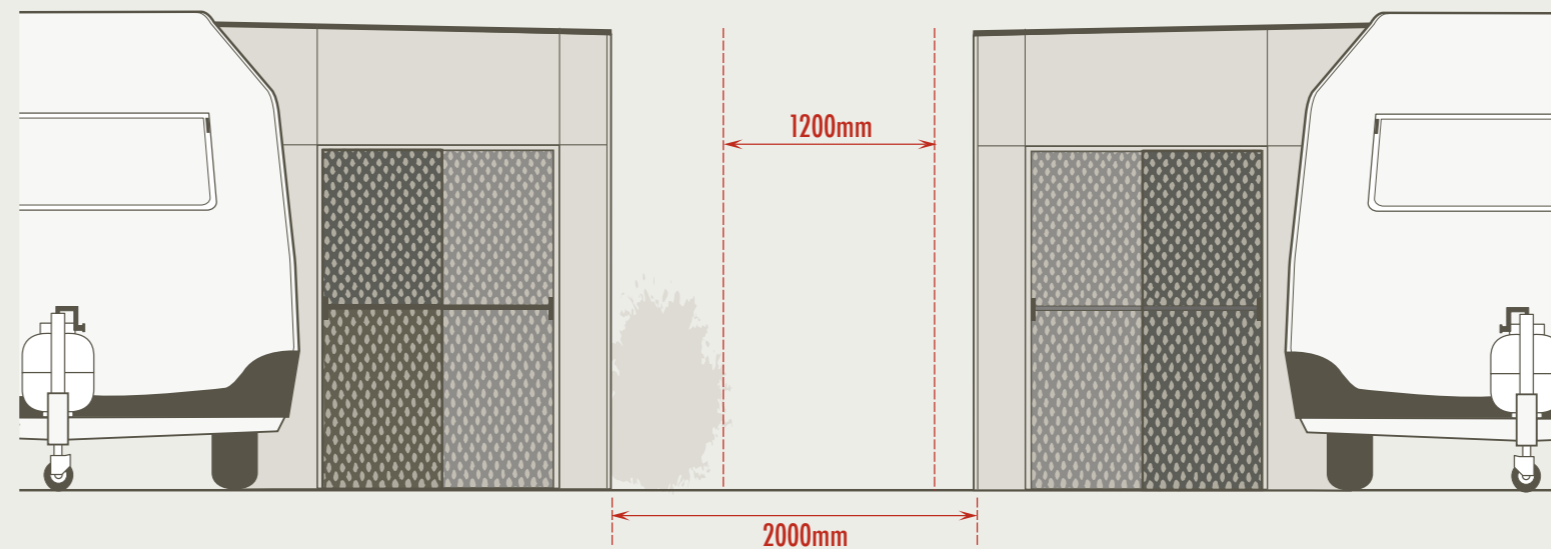

Figure 9 – Solid fly to solid fly fire separation



Prescriptive Provisions

FIREFIGHTER ACCESS



FIRE SEPARATION

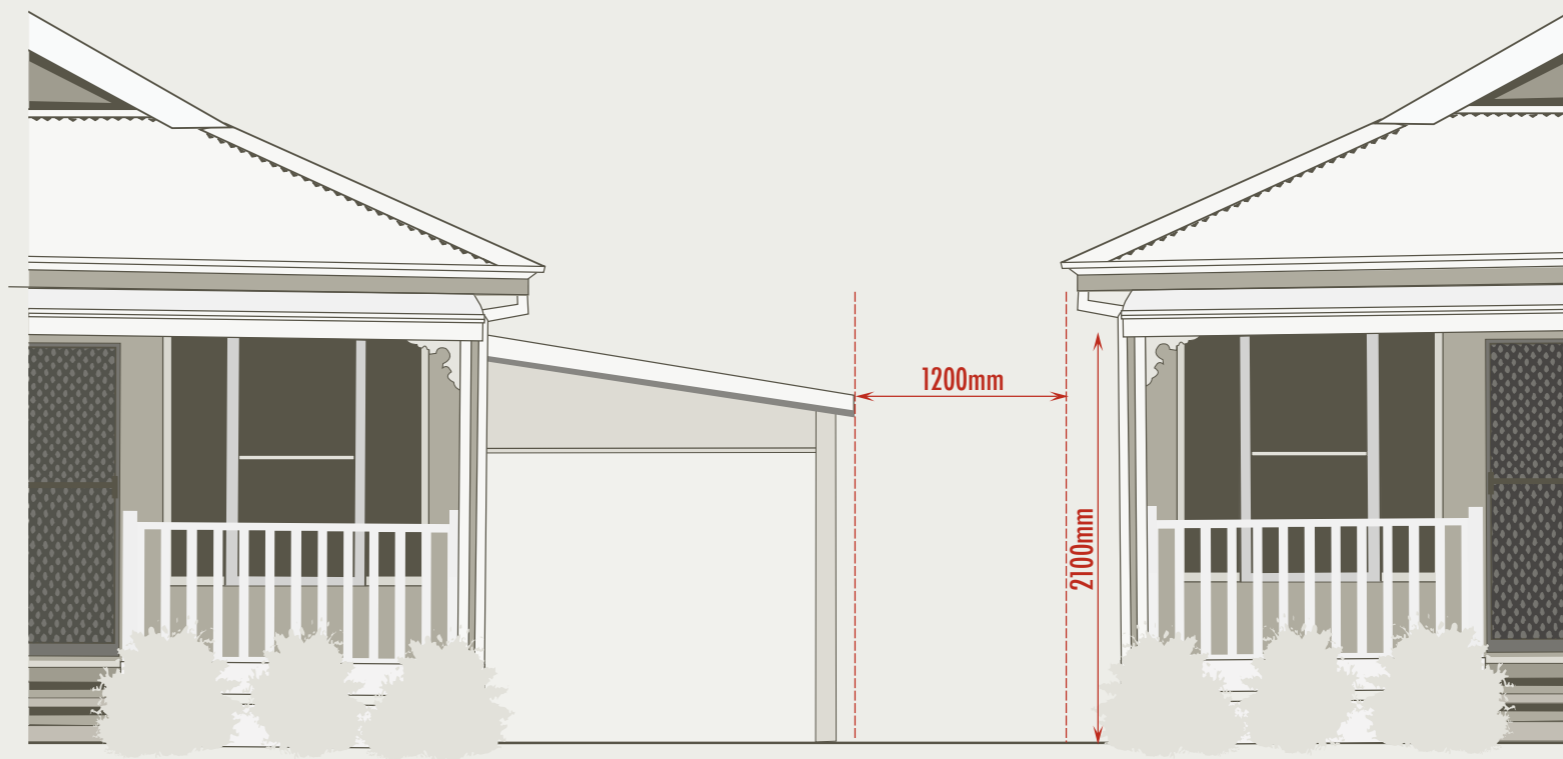

Figure 10 – Movable dwelling to carport movable dwelling fire separation

Note: This configuration will only meet the Prescriptive Provisions if the carport is open on three sides and is not fitted with a roller door or any partitions.

Carports with roller doors, partitions etc., must be a minimum of 2000mm from the external wall of the adjoining structure.



Prescriptive Provisions

FIREFIGHTER ACCESS



FIRE SEPARATION

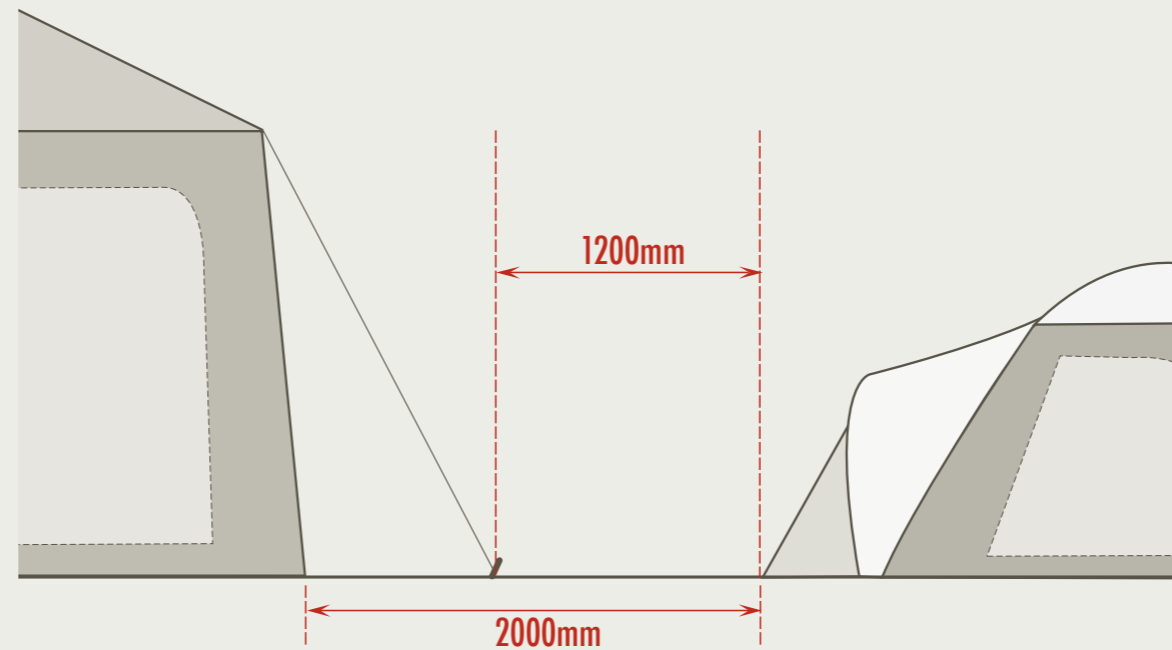

Figure 11 – Tent to tent fire separation



Note: To meet Prescriptive Provisions, these access and separation distances are required between tent *sites*, not necessarily between individual tents.



Prescriptive Provisions

FIREFIGHTER ACCESS



FIRE SEPARATION



Figure 12 – Plan view of required firefighter access and fire separation distances

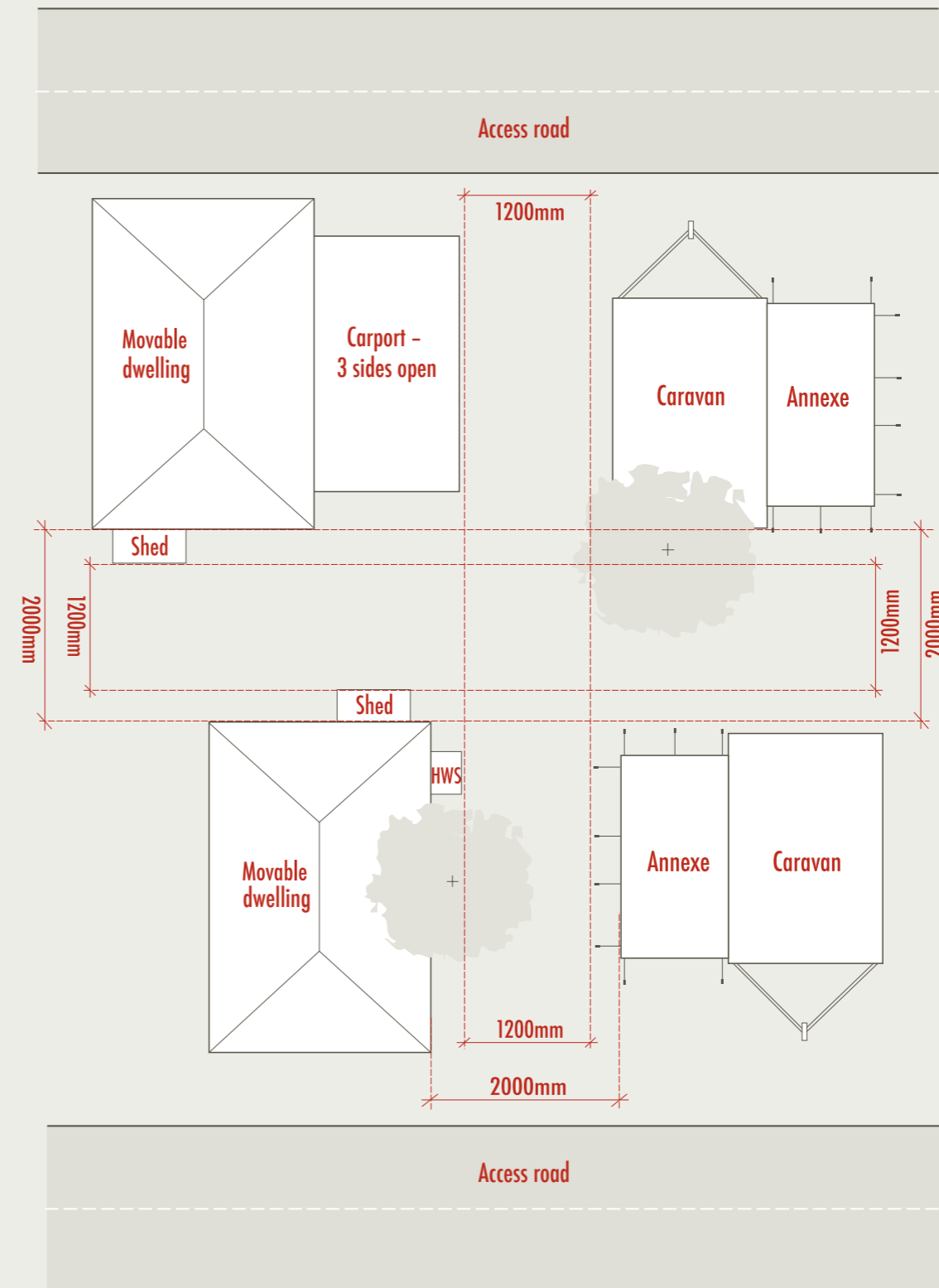



Prescriptive Provisions

FIREFIGHTER ACCESS



FIRE SEPARATION



Rationale – Firefighter access and fire separation

The Regulations specify that firefighter access is required to be provided. Additionally, Victorian Fire Services consider that fire separation is required to achieve an appropriate level of fire safety. Fire service research shows that 1200mm width is required for firefighters to operate effectively. This width is required to allow firefighter manoeuvrability and tasks including patient rescue, and the use of ladders and fully charged hoses.

Caravan parks often have a number of *movable dwellings* and other permanent *structures*. Increasingly, there is a trend for *movable dwellings* to become more home-like, with occupants staying

long-term or becoming permanent residents at the caravan park. This can mean that people are living in close proximity to neighbours with a risk of fire spreading to their home.

One of the key elements of Building Regulations in Victoria is to protect a dwelling from fire spread and avoid the spread of fire between dwellings. *Movable dwellings*, caravans and tents should be treated no differently. Therefore, the fire separation principles in this guideline are based on the Building Regulations and Building Code of Australia for class 1a single dwellings, which allows for the combustibility of typical *structures* found in caravan parks. ▶



Prescriptive Provisions

FIRE VEHICLE ACCESS



PP2 Fire vehicle access

Fire vehicle access (in accordance with regulation 21) must be provided within a caravan park as follows:

- a. Curves in a driveway must have a minimum inner radius of 10 metres (refer Figure 13 below).

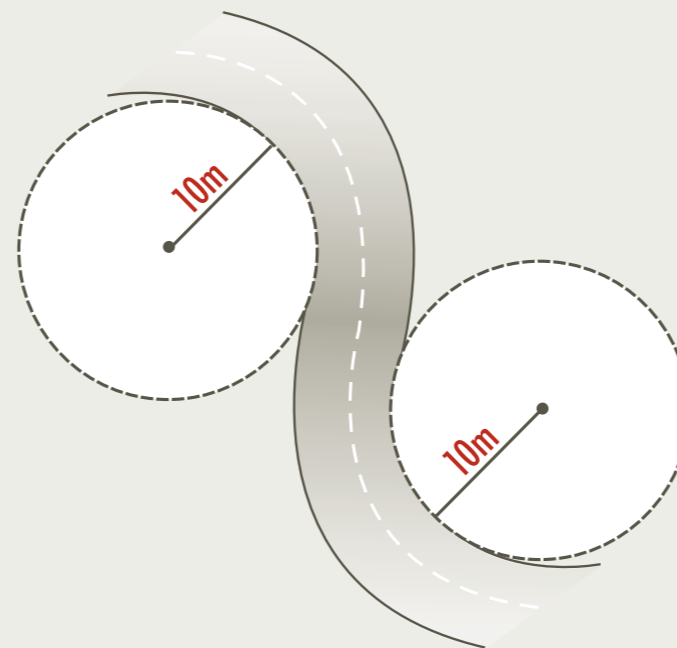

Figure 13 – Driveway radius





Prescriptive Provisions

FIRE VEHICLE ACCESS



PP2 Fire vehicle access

- b. The average grade on roads within the caravan park must be no more than 1 in 7 (14.4%) (8.1 degrees) with a maximum of no more than 1 in 5 (20%) (11.3 degrees) for no more than 50 metres (refer Figure 14 below).

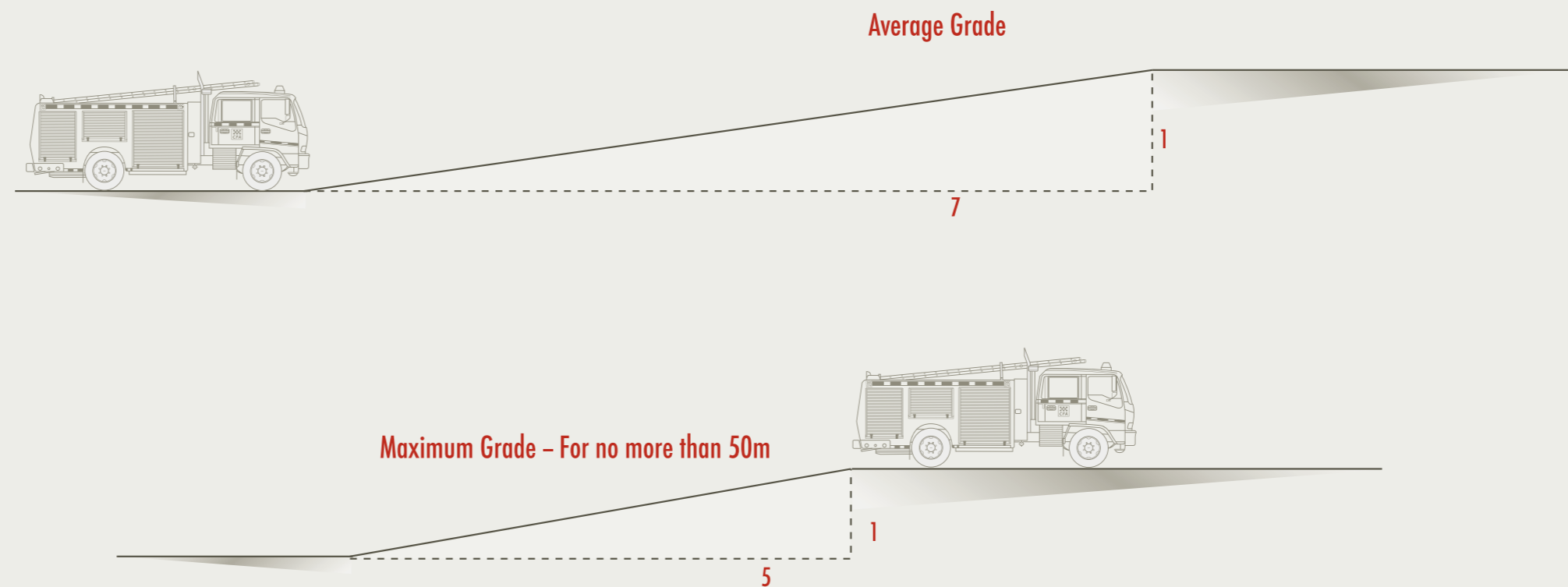

Figure 14 - Gradient





Prescriptive Provisions

FIRE VEHICLE ACCESS



PP2 Fire vehicle access

- c. Dips must have no more than 1 in 8 (2.5%) (7.1 degrees) entry and exit angle (refer Figure 15 below).

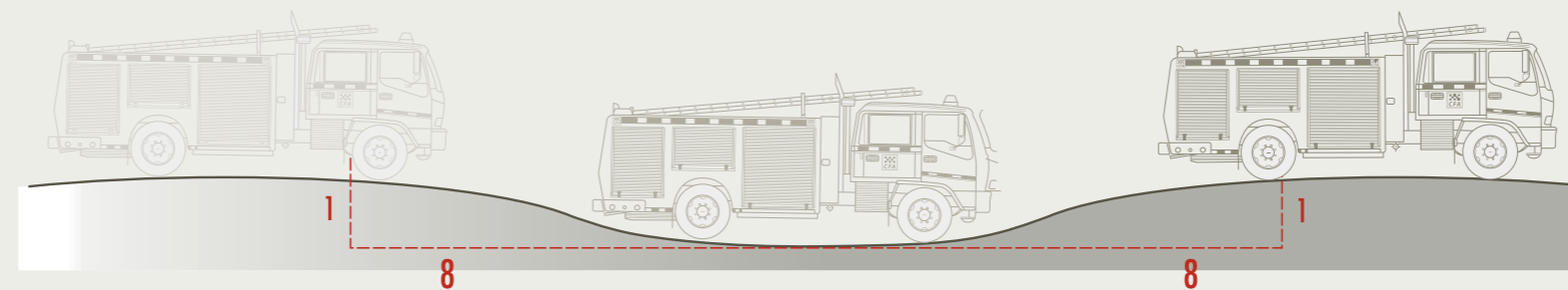

Figure 15 - Dips





Prescriptive Provisions

FIRE VEHICLE ACCESS



PP2 Fire vehicle access

The access road must:

- d. be designed, constructed and maintained for a load limit of at least 15 tonnes and be of all-weather construction and;
 - i. provide a minimum trafficable width of 4 metres and be clear of encroachments 4 metres vertically (refer Figure 16, below);
 - ii. if the access road is longer than 100 metres from the nearest intersection, it must have
 - a turning circle with a minimum radius of 10 metres; or
 - a "T" or "Y" head with a minimum formed surface of each leg being 8 metres in length, measured from the centre point of the head and 4 metres trafficable width (refer Figure 17);
 - iii. if the length of the access road is greater than 200 metres, passing bays must be provided. Passing bays must be 20 metres long and be provided every 200 metres with a trafficable width of 6 metres (refer Figure 18 following).

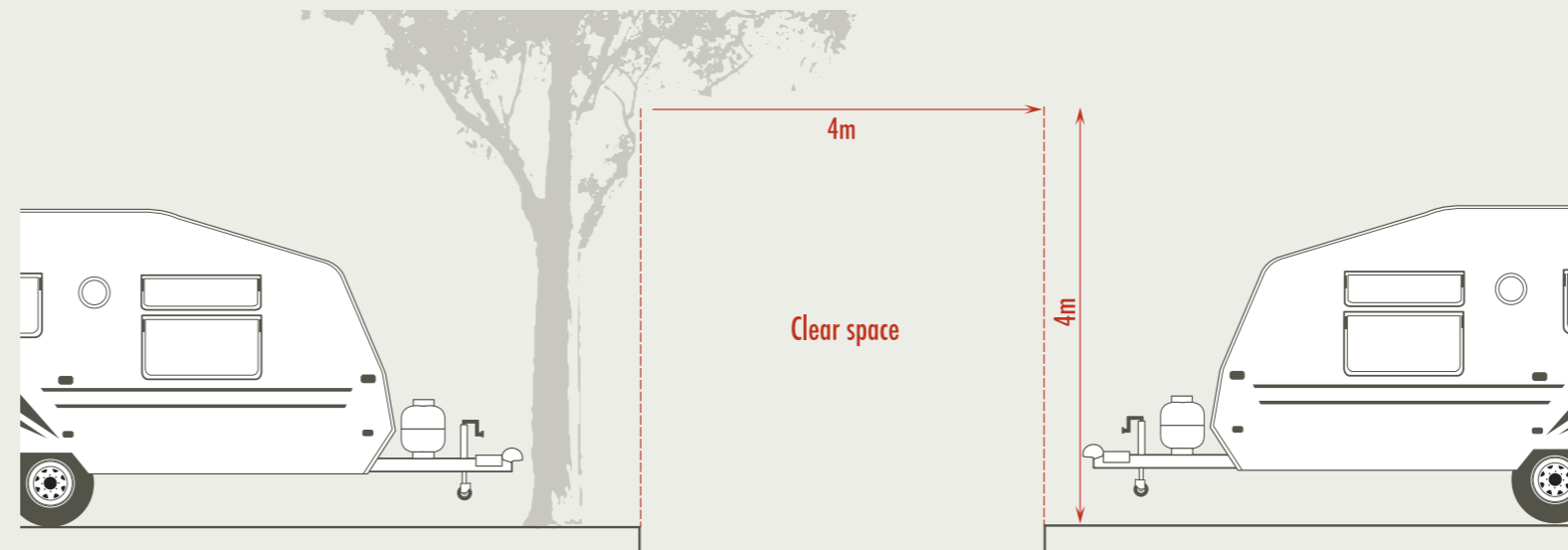

Figure 16 – Trafficable width and height



Prescriptive Provisions

FIRE VEHICLE ACCESS



PP2 Fire vehicle access

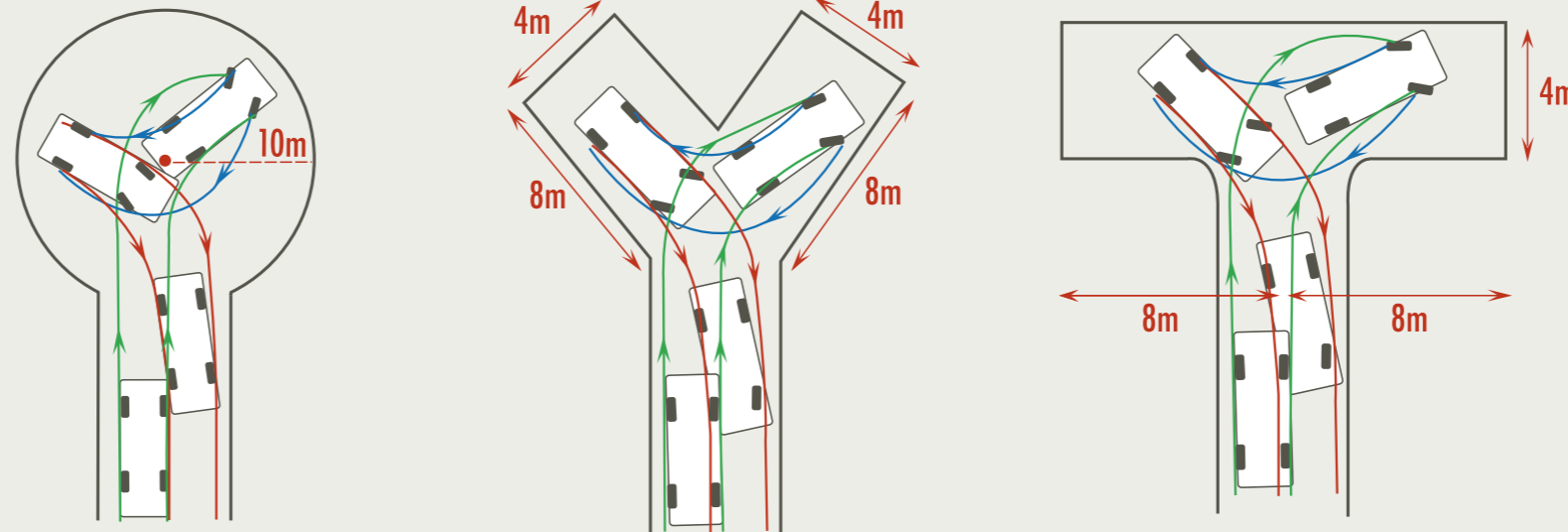

Figure 17 – Access/turning circle





Prescriptive Provisions

FIRE VEHICLE ACCESS



PP2 Fire vehicle access

To the *degree necessary*, site plans must be provided at every vehicle entrance point to the caravan park and:

- a. be legible at all times; and
- b. include:
 - i. road network and road names;
 - ii. *site* layout and numbering;
 - iii. water supply and hydrant locations; and

Road signs must be provided.

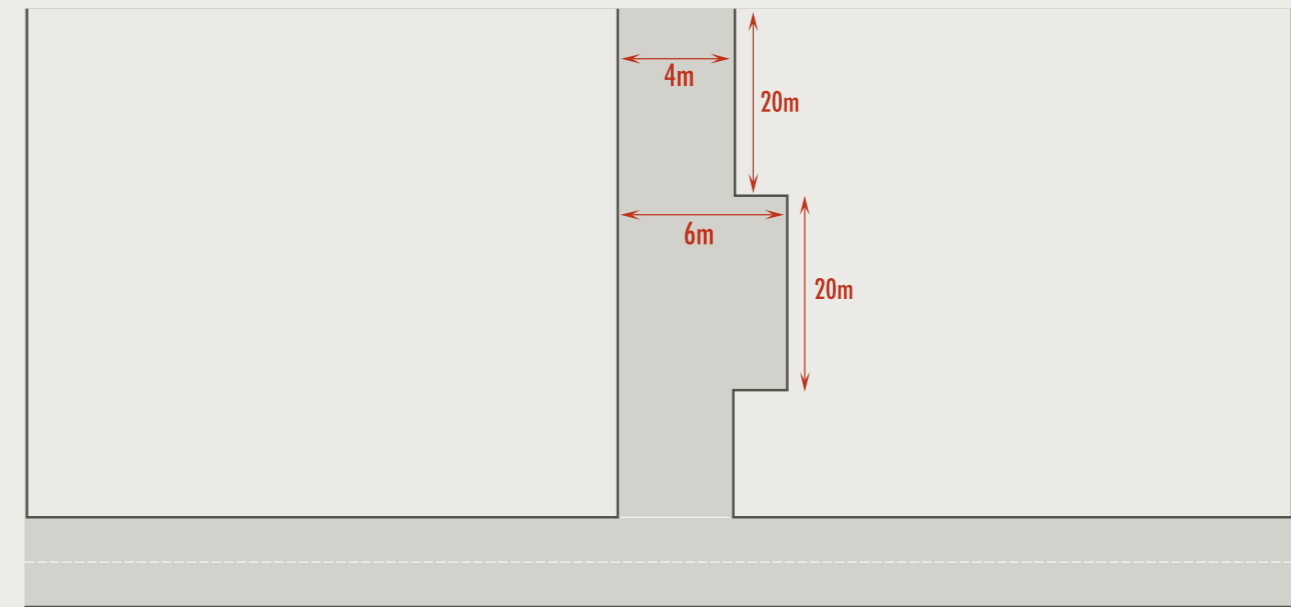

Figure 18 – Access road length/passing bays





Prescriptive Provisions

FIRE VEHICLE ACCESS



Rationale – Fire vehicle access

Steep slopes and severe short dips affect the free movement of fire trucks and limit operational capabilities. Roads must be trafficable in all weather conditions and should be constructed to suit a 15-tonne Gross Vehicle Mass (GVM). Although most fire trucks weigh less than 13 tonnes, future trucks and some current vehicles weigh more than this.

It is dangerous for emergency services vehicles to reverse along roads for excessive distances, especially in an emergency situation. Access roads must incorporate the ability for fire trucks to execute a three-point turn safely and permit other emergency services vehicles to pass.

Firefighters arriving at a caravan park are often faced with a difficult task of navigating vehicles efficiently to an emergency. Factors include caravan park size, complexity of roads and lack of verifiable information from the caller. Adequate on-site information can overcome this. ▶



Prescriptive Provisions

OCCUPANT FIRE EQUIPMENT



PP3 Occupant fire equipment

Each residential *structure* (excluding tents) within the caravan park must be provided with:

- a. portable fire extinguishers, selected and installed in accordance with AS 2444 (including signage), maintained to the appropriate standard and fit for purpose;
- b. fire blankets selected and installed in accordance with AS 2444 (including signage), maintained to the appropriate standard and fit for purpose; and
- c. smoke alarms complying with AS 3786 (these may be battery operated or hardwired), maintained to the appropriate standard and fit for purpose.

It is acknowledged that caravan park owners may be unable to demonstrate compliance with **Prescriptive Provision PP3** in relation to privately owned caravans. However, private caravan owners should be encouraged to comply with this provision.

Each *site* must be provided with full coverage from 36 metre-long fire hose reels (when fully extended and laid to avoid any physical barriers). Fire hose reels are to be installed in accordance with AS 2441 as if they were being installed to a building, be maintained to the appropriate standard and be fit for purpose (refer Figure 19 following). All fire hose reels must be provided with protection from the weather.

In areas where reticulated water supply is not available, static water supply may be considered to serve fire hose reel systems. Connection to the static water supply may be provided for the fire service. ▶



Prescriptive Provisions

OCCUPANT FIRE EQUIPMENT

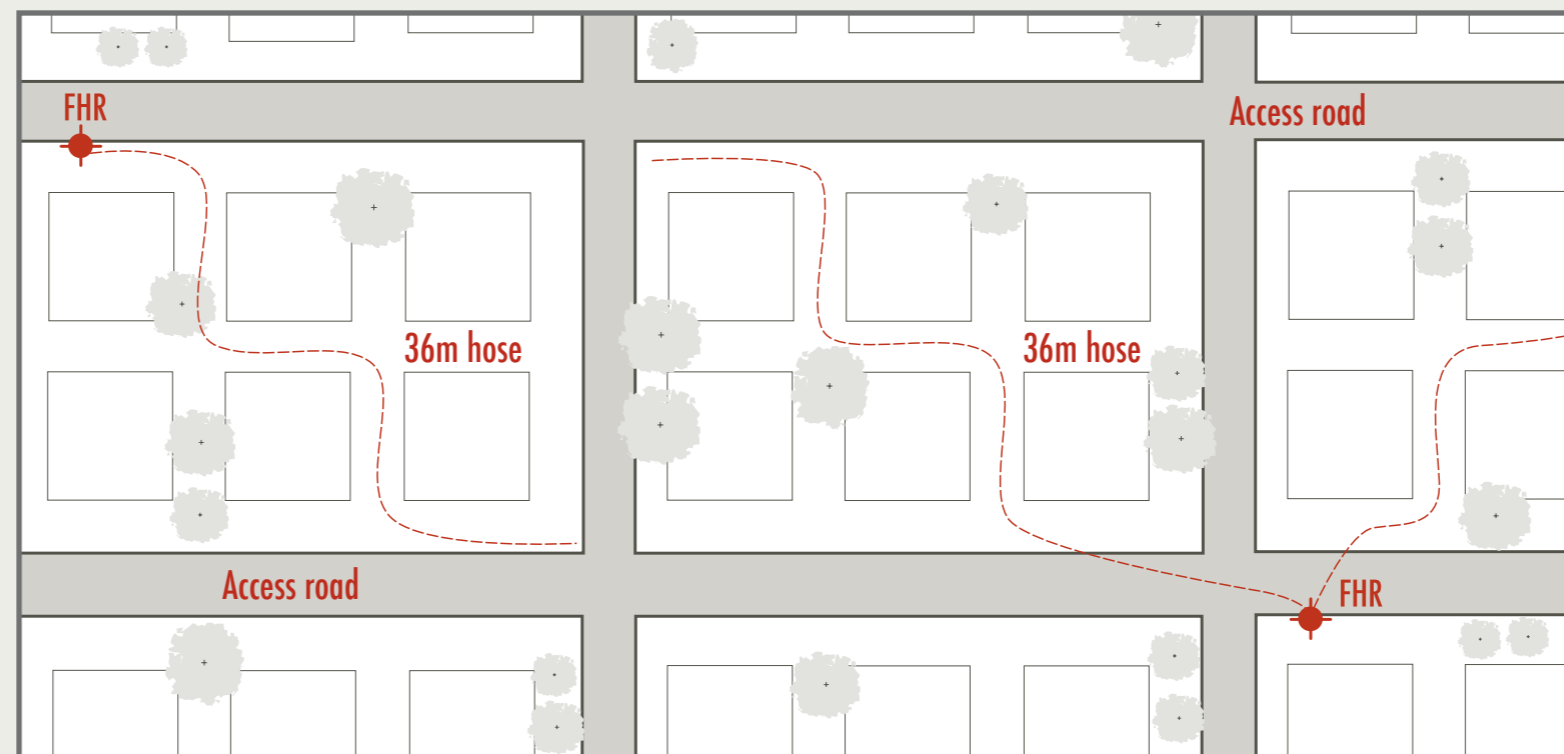

Figure 19 – Fire hose reel (FHR) coverage





Prescriptive Provisions

OCCUPANT FIRE EQUIPMENT



Rationale – Occupant fire equipment

Occupants must be notified of a fire as soon as possible and provided with the opportunity to extinguish it or reduce fire spread prior to the arrival of fire services. Occupant fire equipment must be reliable and effective. Fire service response times in regional areas are increased as a result of distance and resources, therefore occupant intervention may be critical in reducing the size and impact of fire. ▷



Prescriptive Provisions

FIRE AUTHORITY EQUIPMENT



PP4 Fire authority equipment

A reticulated fire hydrant system is to be provided within the caravan park:

- so that 120 metres of hose, laid to avoid all permanent obstructions and anticipated vehicular obstructions, will provide coverage to every *site* and *structure* (refer Figure 20); and
- to meet the water performance, pipe size and fitting requirements of AS 2419.1 as if they were being installed to protect a building, to the satisfaction of Victorian Fire Services; and
- with external hydrants pursuant to section 3.2.2.2 of AS 2419.1 (refer Figure 20).

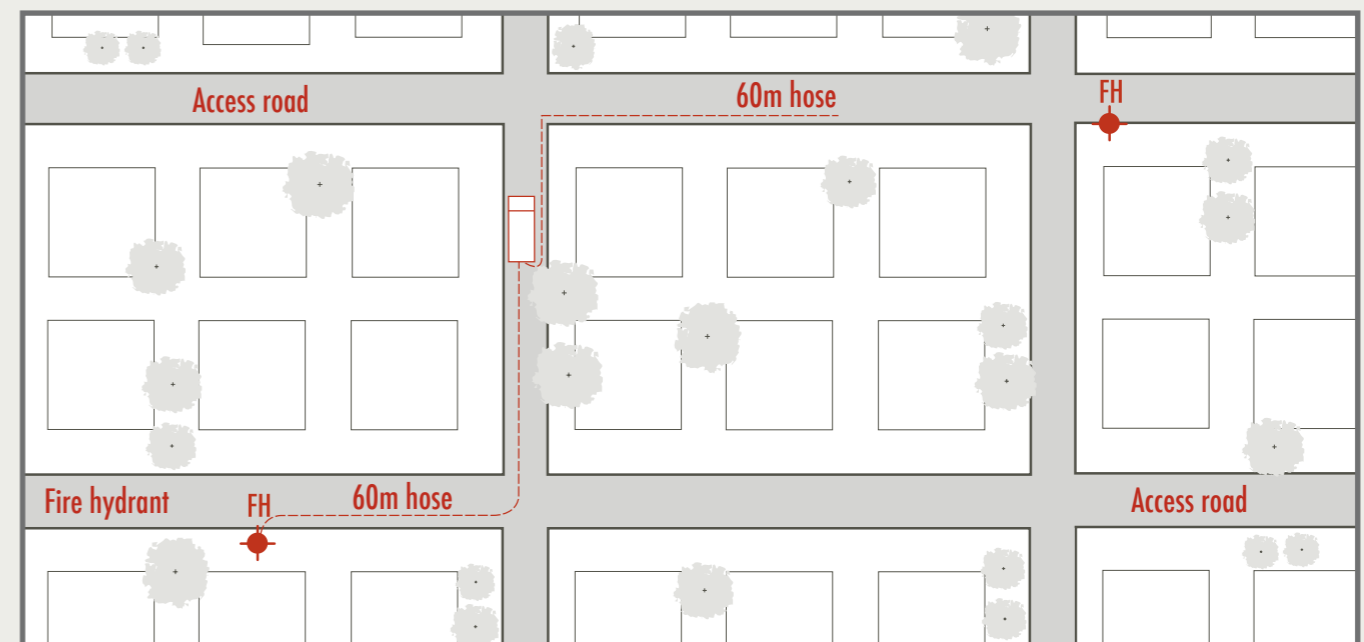

Figure 20 – Reticulated fire hydrant coverage





Prescriptive Provisions

FIRE AUTHORITY EQUIPMENT



PP4 Fire authority equipment

If a reticulated fire hydrant system is not provided, a static water supply must be provided to the caravan park:

- a. with a maintained minimum water supply of 45,000 litres exclusively for firefighting use; and
- b. meet the water performance, pipe size, tank construction and fitting requirements of AS 2419.1 as if it was being installed to protect a building, to the satisfaction of Victorian Fire Services; and
- c. located so that every *site* and *structure* is within reach of 60 metres of hose laid from the tank or 120 metres of hose laid from a hydrant on a reticulated system connected to the tank, avoiding all permanent obstructions and anticipated vehicular obstructions; and
- d. with tanks located within 4 metres of hardstand to allow fire vehicles to connect to the static water supply to the satisfaction of fire services.

(Note: Larger caravan parks may be required to provide multiple static water supply tanks to achieve coverage (refer Figures 22 and 23). 



Prescriptive Provisions

FIRE AUTHORITY EQUIPMENT



PP4 Fire authority equipment

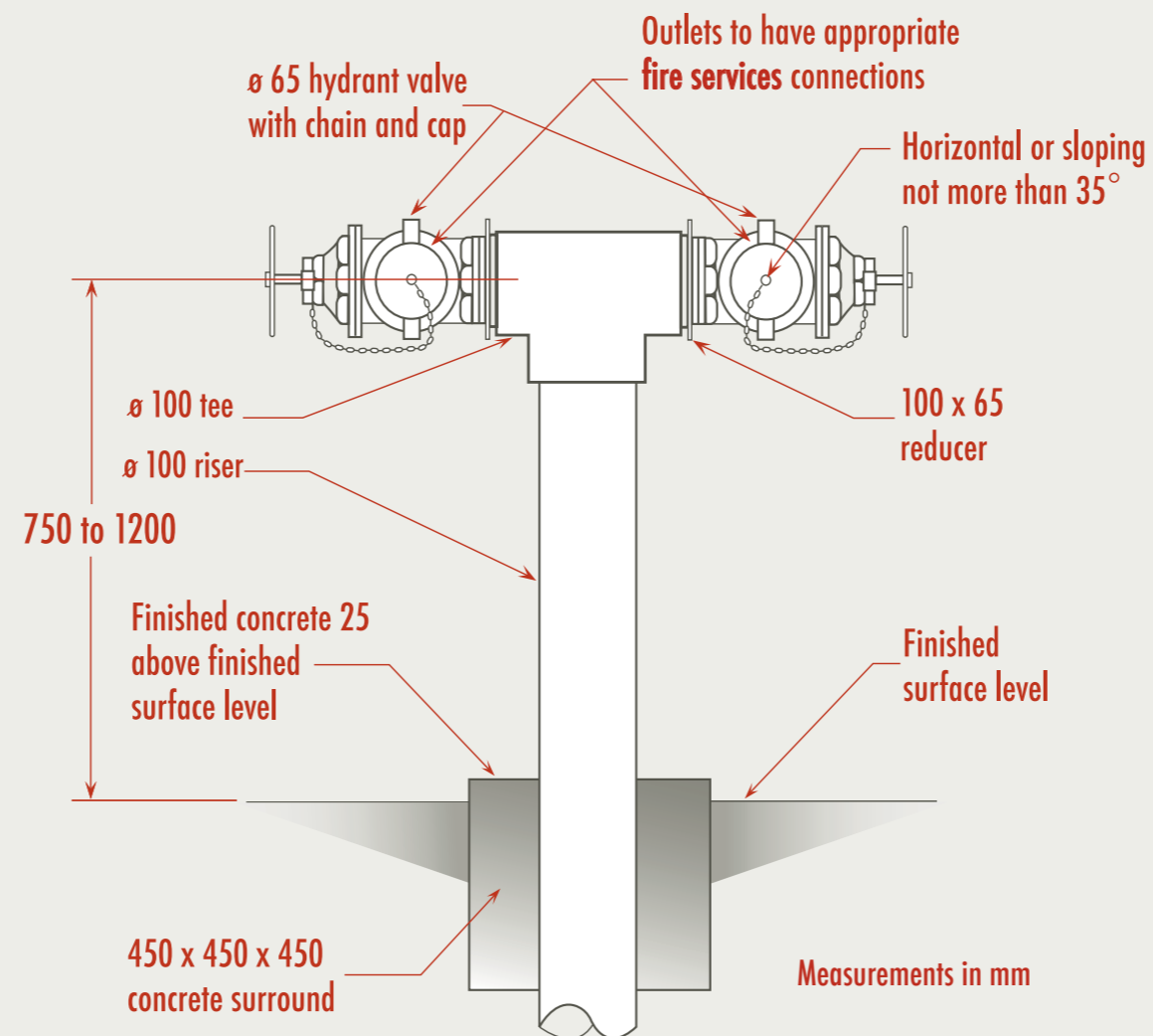

Figure 21 – External fire hydrant pursuant to AS 2419.1





Prescriptive Provisions

FIRE AUTHORITY EQUIPMENT



PP4 Fire authority equipment

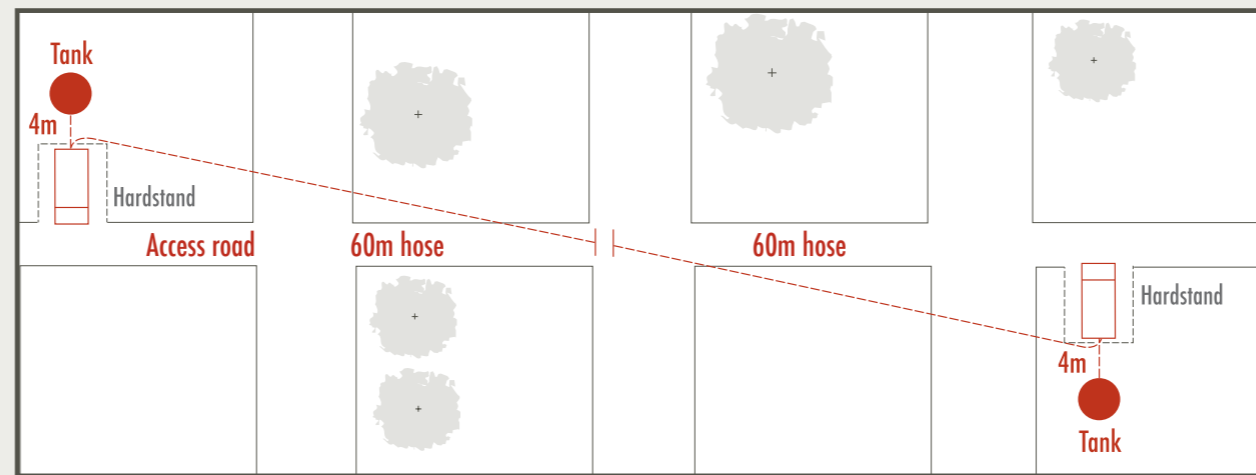

Figure 22 – Static water storage coverage, no reticulation

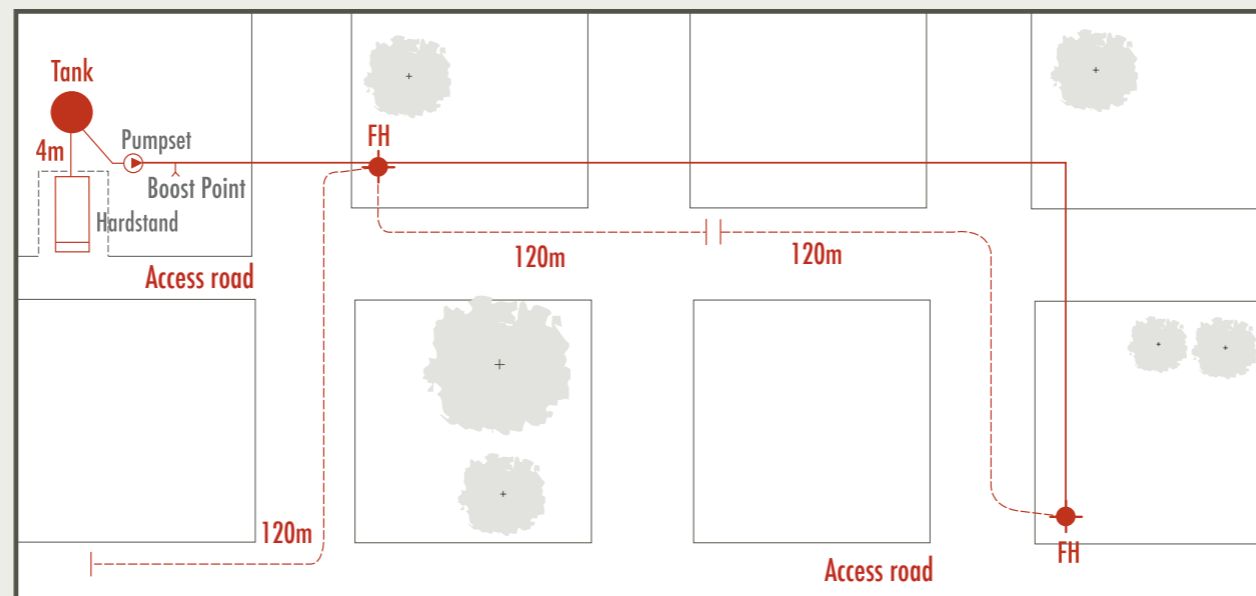

Figure 23 – Static water storage coverage, with reticulation





Prescriptive Provisions

FIRE AUTHORITY EQUIPMENT



Rationale – Fire authority equipment

Fire hydrants are the most effective means of supplying the high volumes of water required by fire brigades. Although responding brigades may include tankers, the amount of water they carry may be insufficient to control or extinguish a fire.

Where reticulated water supply is not available, fire brigades may use on-site stored water.

The Prescriptive Provision assumes that 45,000 litres is sufficient to contain a maximum of four caravans/*movable dwellings*. It also assumes that there will only be one incident at a time.

The hose lengths are determined by operational capacity. Longer lengths create difficulties with set-up time and manoeuvrability and also reduce hydraulic performance. ▶



Prescriptive Provisions

LP GAS



PP5 LP Gas

LP Gas storage and use within caravan parks must be in accordance with AS1596, AS5601 and *Dangerous Goods (Storage and Handling) Regulations 2000*. Information in this regard may be sought from WorkSafe. *Movable dwellings* must comply with AS 5601 Appendix J, as appropriate.

Caravan park owners should ensure that any LP Gas cylinders that are used within the park comply with regulations and are inspected regularly. Owners of *movable dwellings* should also ensure that their LPG cylinders are stored in the correct location and secured in such a way that prevents movement.

Clause 4.5.4 of AS 1596–2008 requires that LP Gas cylinders be secured to prevent movement or physical damage. Valves shall be safeguarded against physical damage in accordance with AS 2473.

Clause 4.4.3 of AS 1596–2008 also sets out the prohibited locations of LP Gas bottles and includes:

- within a building, except where permitted by AS 1596;
- under a stairway;
- in a location with restricted access, where inspection, refilling or exchange of the cylinder is restricted, obscured or hazardous to the operator;
- where nearby constructions, fences, walls or vapour barriers could prevent cross-ventilation;
- under a building, except where permitted by AS 1596;
- where the cylinder, or an incident involving the cylinder and its contents, could obstruct egress from a building; and

- buried in the ground, unless the cylinder and gas installation have been specifically designed for such a location.

For acceptable locations for the installation of LP Gas cylinders and the appropriate dimensions required from dwelling features such as door, vents and openable windows, refer Figure 24 from AS 1596–2008.

Note: *The Victorian Fire Services do not regulate gas safety. The fire services support the requirements of Energy Safe Victoria, as well as the Australian Standards, as part of a holistic fire safety approach.* ▶



Prescriptive Provisions

LP GAS



PP5 LP Gas

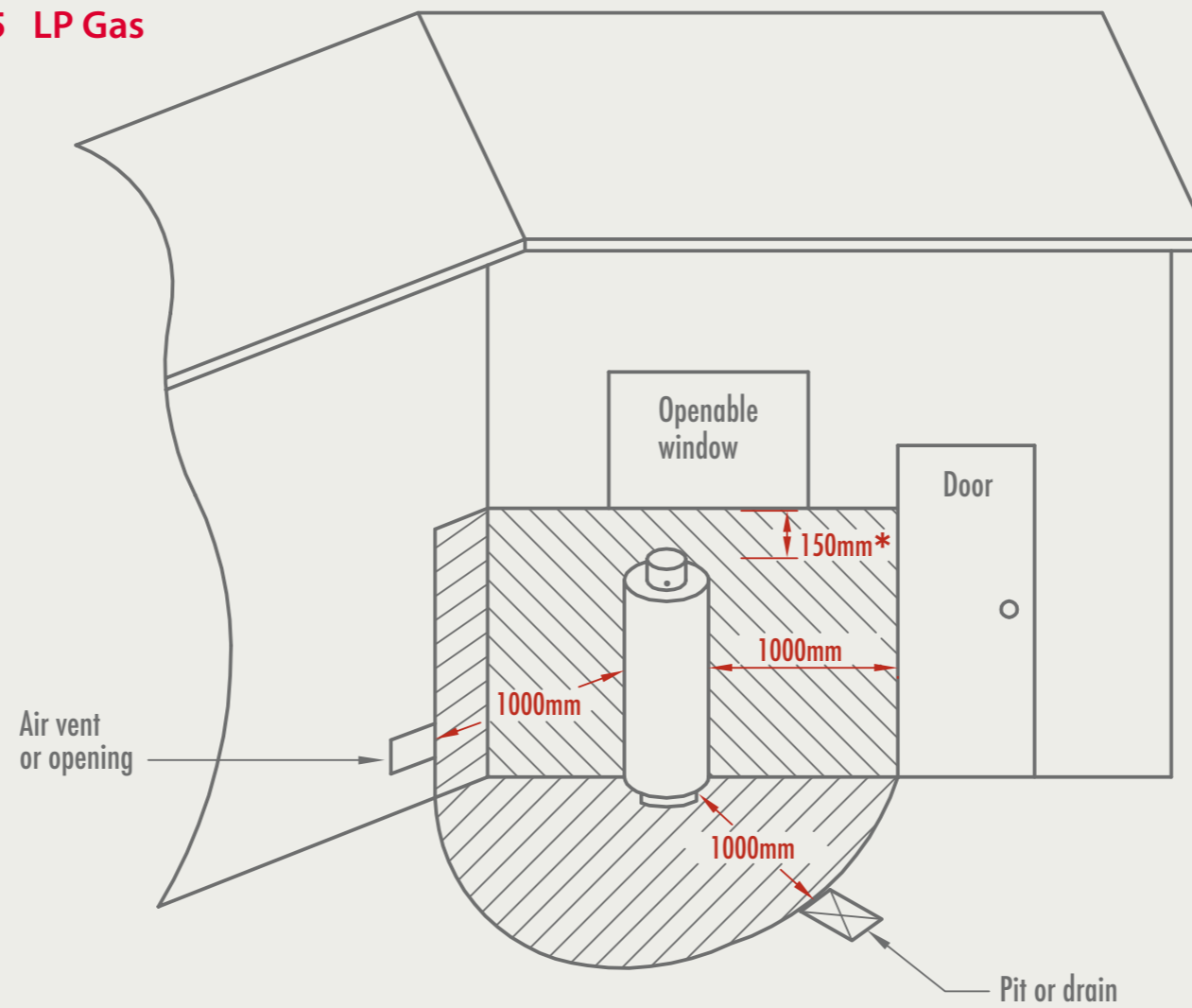

* This distance is measured from the top of any cylinder valve

Figure 24 – Acceptable locations for the installation of LP Gas cylinders



Prescriptive Provisions

LP GAS



Restriction on ignition sources

As gas bottles are fitted with pressure relief devices and vent discharging pipes, it is important that caravan park owners understand how these operate and the direction that the gas bottle may vent.

AS 1596–2008 also makes reference to hazardous areas around gas bottles. Caravan park owners must ensure that sources of ignition are not permitted within a hazardous area. (Refer Figure 25 from AS 1596–2008)

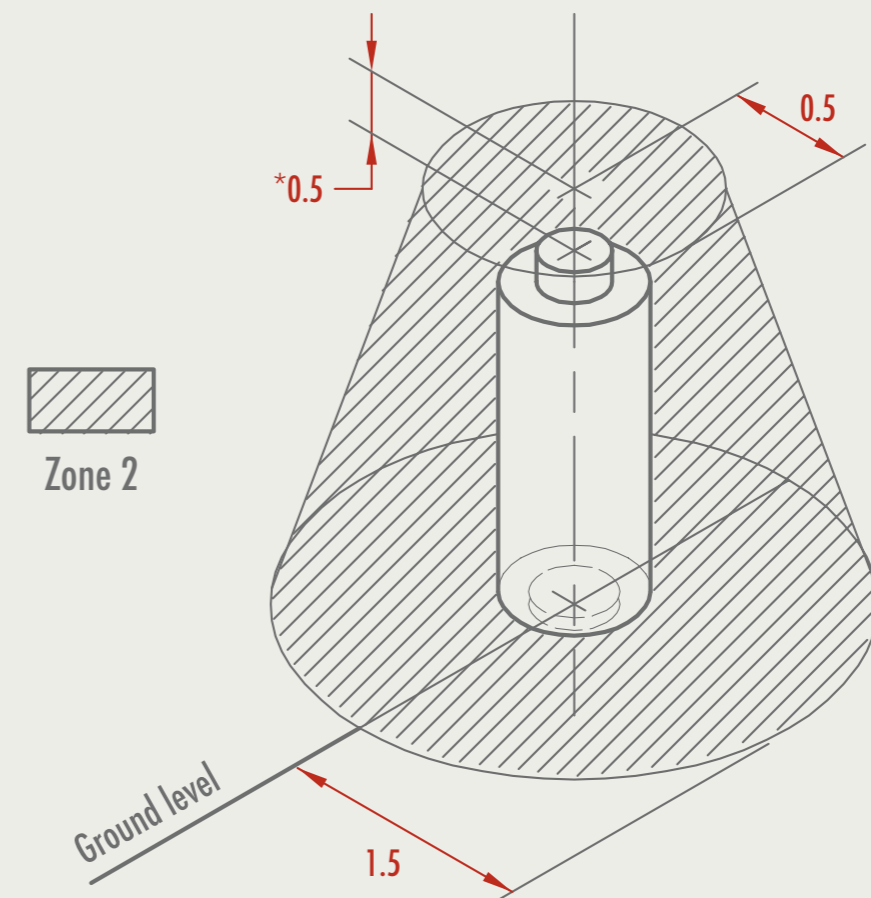

* This dimension is measured from the top of any cylinder valve

Figure 25 – Hazardous areas around gas bottles





Prescriptive Provisions

LP GAS



Ignition source

An ignition source as defined in AS 1596–2008 as:

“a source of energy sufficient to ignite a flammable atmosphere, including naked flames, smoking, exposed incandescent material, electrical welding arcs, static electricity and electrical or mechanical equipment not suitable for use in the particular hazardous zone”.

Caravan park or dwelling owners with service equipment such as hot water units, gas or electric, air conditioning units/condensers, or other spark or piloted equipment should ensure that this equipment is not located within this zone.

Caravan park or dwelling owners who require further information regarding gas safety within a caravan park should contact Energy Safe Victoria.

Caravan parks that store and handle quantities of dangerous goods that exceed those listed under “Manifest Quantity” or “Fire Protection Quantity” in Schedule 2 of the *Dangerous Goods (Storage and Handling) Regulations 2000*, are required to seek specific advice from Victorian Fire Services. Both the CFA and MFB have a Dangerous Goods Unit. Advice from the fire services may require the implementation of measures that exceed those referenced by this guideline in relation to fire safety equipment. This requirement generally applies to the storage of LP Gas in excess of 5,000 litres. ▶



Prescriptive Provisions

LP GAS



Rationale – LP Gas

LP Gas is a highly volatile liquid and must be stored/used appropriately. LP Gas is commonly used in caravan parks and may be stored remotely in large quantities (tank) or smaller cylinders immediately adjacent to accommodation *structures*. Type, location and orientation of use must therefore be determined to reduce the risk of associated fires. ▶



Prescriptive Provisions

ELECTRICAL SAFETY



PP6 Electrical safety

Electrical safety should be promoted in accordance with AS/NZS 3000 and AS/NZS 3001. AS 3001 is a specific standard for electrical installations in transportable *structures* (e.g. caravans) and vehicles. This standard also applies to *site* electrical supplies.

The following guidelines should be followed:

- a. powerlines must be kept clear of vegetation and other obstructions;
- b. external power supply between the source and *structures* within the caravan park must be insulated and not contain any connections exposed to the weather;
- c. supply leads must be arranged so that they will not obstruct persons walking in the vicinity of any *movable dwelling* and are located so as to provide suitable protection against mechanical damage, damage by high temperatures or ultra-violet radiation;
- d. each *site* should have its own individual power source;
- e. each *movable dwelling* should have its own residual current device when the *movable dwelling* is connected to mains power;
- f. the use of multiple power boards and double adaptors should be discouraged; and
- g. extension leads for connection between the external power source and the *structure* should be tested and tagged in accordance with AS/NZS 3760.

Where a supply lead is buried and in an area subject to pegs or anchor stakes that exceed 400mm in length, the supply lead shall be located at a depth of not less than 1 metre or have a continuous pour of concrete placed not more than 75mm above the wiring system. The concrete should have a thickness of at least 100mm and a minimum width of 150mm, overlapping the wiring system by at least 40mm on each side. Alternatively, the buried supply lead should have an equivalent level of mechanical protection.

Note: *The Victorian Fire Services do not regulate electrical safety. The fire services support the requirements of Energy Safe Victoria, as well as the Australian Standards, as part of a holistic fire safety approach.* ▶



Prescriptive Provisions

ELECTRICAL SAFETY



Information that the caravan park owner can provide an occupier

Extract from AS 3001–2008, Appendix B – Provisions of instruction for caravan park patrons:

It is recommended that the caravan park or camping area operators provide all site occupiers intending to connect their transportable structures to the site supply by means of a detachable connection with an instruction notice that conveys the following information:

Only one supply lead shall be connected to each socket-outlet of the site supply.

Any supply lead used to connect a transportable structure to a site supply socket-outlet should be in one unbroken length.

The supply of electricity for use in individual transportable structures or vehicles should not be obtained from a socket-outlet inside another transportable structure or vehicle or by the use of socket-outlet adaptors (double adaptors).

Where a supply lead is coiled on or in a reel, drum, storage box or similar, the lead should not be connected to the site supply while coiled.

Electrical installations in transportable structures should be inspected regularly (e.g. annually), by a qualified person to ensure their safe and effective operation.

Residual Current Devices (RCD) used for the protection of transportable structures should be tested by operating the push button on the RCD to check that the device trips. After tripping, the RCD should be reset. If the RCD fails to trip, this failure should be reported to the caravan park manager.

If supply to a site is lost, the device requiring resetting might be located within the premises or at the service pillar.

Although this information is provided within AS 3001–2008 as “informative” and therefore does not form part of complying with the standard, it provides good information that the park owner/manager can use in managing the risks associated with electricity.

Caravan park and dwelling owners who require further information regarding electrical safety within a caravan park should contact Energy Safe Victoria. 



Prescriptive Provisions

FLAMMABLE LIQUIDS



PP7 Flammable liquids

Storage and use of flammable liquids within caravan parks must be in accordance with *Dangerous Goods (Storage and Handling) Regulations 2000* and AS 1940. Guidance should be sought from WorkSafe.

Caravan parks that store and handle quantities of dangerous goods that exceed those listed under "Manifest Quantity" or "Fire Protection Quantity" in Schedule 2 of the *Dangerous Goods (Storage and Handling) Regulations 2000* are required to seek specific advice from fire services. This advice may require the implementation of measures that exceed those referenced by this guideline in relation to fire safety equipment. This requirement generally applies to the storage of flammable liquids in excess of 2,500 litres. ▶



Prescriptive Provisions

FLAMMABLE LIQUIDS



Rationale – Flammable liquids

Flammable liquids are highly volatile and must be stored and used appropriately. Flammable liquids storage areas should be at least 3 metres away from any dwellings and positioned to prevent a further hazard. Vapours from fuel such as petrol and kerosene are heavier than air and will therefore settle in low spots such as drains. Caravan park facilities should also be equipped with a means of handling small spills with a non-leaching, biodegradable oil and chemical absorbent. ▶



Prescriptive Provisions

EMERGENCY MANAGEMENT PLAN



PP8 Emergency management plan

Pursuant to regulation 22 of the *Residential Tenancies (Caravan Parks and Movable Dwellings Registration and Standards) Regulations 2010*, emergency management plans must be developed for each caravan park. Emergency management plans should be developed in accordance with AS 3745 and AS/NZS 4360.

AS 1596 and AS 1940 also have a requirement for the provision of emergency management plans as does the *Dangerous Goods (Storage and Handling) Regulations 2000* where the storage thresholds are met. These standards and regulations impose greater information and consideration than that required by AS 3745. Therefore each caravan park should investigate whether or not any additional obligations exist under AS 1596, AS 1940 or *Dangerous Goods (Storage and Handling) Regulations 2000*.

Emergency management plans must be prepared in consultation with the relevant emergency services. Caravan park owners will need to engage all the relevant services.

The emergency management plan must be located in a prominent position that is acceptable to all of the emergency services, but will generally be the park main office.

Each of the emergency services, including the Victorian Fire Services, can provide assistance in the development of appropriate emergency management plans.

Display of emergency warnings

Regulation 24 requires a caravan park owner to display a copy of any public emergency warnings on any day that the warning is current. It must be displayed in a prominent position in:

- the caravan park office;
- every building in the caravan park that contains communal facilities; and
- any other place determined by the council.

On receiving an emergency warning for example, "Code Red" for bushfires, the caravan park owner must implement the relevant emergency procedures in accordance with the emergency management plan.





Prescriptive Provisions

EMERGENCY MANAGEMENT PLAN



Rationale – Emergency Management plans

An emergency management plan is an essential part of fire safety in any facility containing multiple, unrelated occupants. Emergency situations are always time-critical and efficient actions provide positive results. However, emergency management plans must be *site-specific*.

Bushfire risks in caravan parks are obviously increased in regional areas and emergency management plans must take account of this.

The extent of bushfire risk is subject to a number of variables. These include surrounding vegetation, topography, location in relation to manageable land and *site* boundaries, *site* access and brigade resources.

Sound emergency management plans must assess all risks associated with the caravan park. Risks associated with the storage and handling of dangerous goods should also be accounted for appropriately by emergency management plans. ▶



Other guidance information

Provisions for maintenance

Maintenance is essential to ensure that fire prevention and safety equipment, access and separation will perform at the same level of operation that existed at the time of installation and/or commissioning.

Throughout the Regulations and this guideline the provision of maintenance is included and must be undertaken to meet the Performance Measures and comply with the Regulations.

Regulations 20 and 21 require that the provision of fire prevention and safety equipment and access and separation are provided and maintained.

Division 4 of the Regulations (Regulations 43–46) generally require that *movable dwellings* are maintained:

- in working order;
- in a good state of repair; and
- in a clean, sanitary and hygienic condition.

Regulation 46 also requires park owners and the short-term occupier to keep the *site* clean and free of any thing or substance that may affect the health and safety of other persons. ▶



Other guidance information

Rationale – Maintenance

Reasons for ensuring maintenance of various fire safety equipment could be general wear and tear, reliability of a system operating and any faults after commissioning of a system.

Fire prevention and safety systems need to be maintained at a level of performance specified, usually by an Australian Standard, through periodical inspections and checks or other specified

method. Records of the maintenance inspections and checks providing proof of maintenance should also be kept.

Where fire safety systems are not maintained the risk to the park owner increases. For example if the fire services cannot find the hydrant because the garden bed is overgrown or location signage is missing, valuable time is lost trying to locate the hydrant, increasing the risk of fire spread.

The type and frequency of maintenance of fire safety equipment is dependent on the complexity of the equipment and the experience of the person carrying out the inspection. Where appropriate, some equipment may be maintained by the owner. More complex systems, such as hydrants and hose reels, will need to be serviced by a service installer, maintenance contractor or internal maintenance personnel.

Where the owner appoints a person to undertake the maintenance they must ensure that the person

is appropriately qualified and competent to undertake the work.

Therefore, only a qualified and licensed person can undertake such work. Where other tasks can be carried out by a 'competent person' who does not have formal qualifications, such a person must still be able to demonstrate they have the necessary training, qualification or experience, (or a combination of them), to carry out the inspecting and testing task in a competent manner. ▶



Other guidance information

Rationale – Maintenance personnel

A competent person is a person who has acquired – through training, qualification or experience (or a combination of them) – the knowledge and skills enabling the person to perform the task correctly. In the context of this guideline, that person would need to be competent in inspecting and testing fire safety systems. Whoever is responsible for ensuring a particular task is carried out must determine that the person engaged to carry out that task is competent to do so.

In determining a person's competency, due consideration must be given to their qualifications, the training they have received relevant to the task at hand, and their previous experience in doing similar tasks. Some tasks – for example electrical or plumbing installation, inspection and testing – will require a particular competence, such as a formal qualification and/or licence.

Generally, the nature and frequency of maintenance is not prescribed within this guideline or the Regulations because it will vary greatly depending on the type of equipment, its age and the conditions under which it operates.

However, advice may be sought from the Victorian Fire Services or other suitably qualified person, such as building surveyors (private or municipal), services engineers or maintenance firms on maintaining fire

safety systems within the park. Generally this advice will be based on documentation such as AS 1851 as published from time to time. Park owners should also list the items that are required to have regular ongoing maintenance. In preparing the list, park owners should seek advice about the level and frequency of maintenance required from the maintenance personnel listed above. ▶



Other guidance information: Maintenance and inspection records

Specific advice on smoke alarms (Regulations 43 and 45)

Smoke alarms in *movable dwellings* should be tested by the park owner at the change of each occupier. Any owner of a *movable dwelling* within a caravan park must also ensure that the smoke alarms are in working order if they hire out the *movable dwelling* to a short-term occupier.

Maintenance and inspection records

Although the Regulations do not specify any level of documentation to be kept by the owner, the Victorian Fire Services recommend that records of maintenance should be completed. As a minimum, hard copy of records of maintenance can then be made available to organisations such as Victorian Fire Services, local councils and insurance surveyors when requested.

Any maintenance records should contain the following information:

- record reference;
- name and address of caravan park;
- date of maintenance/inspection;
- system or equipment identification and location (possibly a location plan);
- frequency of maintenance activity undertaken;
- defects identified;
- name of property owner or the agent;
- name and signature of the service person; and
- date the record was completed.

Maintenance records may be electronically based or in the form of log books. Hard copy records may be prepared utilising electronic recording systems, which are designed to deliver an accurate, accountable, consistent and timely level of service. ▶



Other guidance information: Maintenance and inspection records

Firefighter access and separation

Essential safety measure to be inspected or tested	Installation standards/level of performance	Nature of inspection or test and frequency of inspection or test
Firefighter access	Caravan Park Guidelines	Annual inspection to ensure that: <ul style="list-style-type: none">■ clearance and access has been maintained; and■ no storage of materials has occurred within the fire separation requirements.



Other guidance information: Maintenance and inspection records

Fire vehicle access and navigation

Essential safety measure to be inspected or tested	Installation standards/level of performance	Nature of inspection or test and frequency of inspection or test
Fire vehicle access	Caravan Park Guidelines	Annual inspection to ensure that: <ul style="list-style-type: none">■ clearances and access is maintained;■ there is no obstruction; and■ roadways are in good order.
Fire vehicle navigation aids	Caravan Park Guidelines	Annual inspection to ensure that signage and other aids are in approved locations and in good working order.



Other guidance information: Maintenance and inspection records

Fire separation

Essential safety measure to be inspected or tested	Installation standards/level of performance	Nature of inspection or test and frequency of inspection or test
Fire separation	Caravan Park Guideline	Annual inspection to ensure that: <ul style="list-style-type: none">■ separation has been maintained as approved; and■ no storage of materials has occurred within the fire separation requirements.



Other guidance information: Maintenance and inspection records

Firefighting equipment

Essential safety measure to be inspected or tested	Installation standards/level of performance	Nature of inspection or test and frequency of inspection or test
Fire extinguishers (portable)	AS 2444 (as published at the time of installation)	As per AS 1851 <i>Maintenance of fire protection systems and equipment</i> (as published at the time of installation).
Fire blankets	AS 2444 (as published at the time of installation)	As per AS 1851 <i>Maintenance of fire protection systems and equipment</i> (as published at the time of installation).
Fire hose reels	AS 2441 (as published at the time of installation)	As per AS 1851 <i>Maintenance of fire protection systems and equipment</i> (as published at the time of installation).



Other guidance information: Maintenance and inspection records

Fire authority equipment

Essential safety measure to be inspected or tested	Installation standards/level of performance	Nature of inspection or test and frequency of inspection or test
Fire hydrants	AS 2419 (as published at the time of installation)	As per AS 1851 <i>Maintenance of fire protection systems and equipment</i> (as published at the time of installation).
Static water storage	Caravan Park Guidelines, AS 2419 (as published at the time of installation)	As per AS 1851 <i>Maintenance of fire protection systems and equipment</i> (as published at the time of installation).



Checklist

Caravan park owners can use the checklist to identify any issues that they may need to address or seek advice about. This checklist may help a park owner identify issues that may need to be addressed through emergency management planning and a suitable risk-treatment process.

The checklist is based on the Prescriptive Provisions. This list is indicative only.

Caravan park owners must read the guideline to make a reasonable judgment regarding full compliance. 



Checklist

Provision for maintenance and access

PRINT-FRIENDLY VERSION

	Yes	No	Comments
Firefighter access – compliant access provided?	<input type="checkbox"/>	<input type="checkbox"/>	
Fire separation – compliant separation provided?	<input type="checkbox"/>	<input type="checkbox"/>	
Vegetation – managed between and around <i>structures</i> ?	<input type="checkbox"/>	<input type="checkbox"/>	
Storage – managed between and around <i>structures</i> ?	<input type="checkbox"/>	<input type="checkbox"/>	
Fire vehicle access – maintained and trafficable?	<input type="checkbox"/>	<input type="checkbox"/>	
<i>Site plans</i> – provided at all vehicle entries show roads, hydrants and water supply?	<input type="checkbox"/>	<input type="checkbox"/>	

RESET

SAVE





Checklist

Prevention of fire spread

PRINT-FRIENDLY VERSION

	Yes	No	Comments
Portable fire extinguishers – correct type selected, installed?	<input type="checkbox"/>	<input type="checkbox"/>	
Fire blankets – correct type selected and installed?	<input type="checkbox"/>	<input type="checkbox"/>	
Smoke alarms – installed?	<input type="checkbox"/>	<input type="checkbox"/>	
Hose reels – installed 36m hose. Do they provide coverage to all areas?	<input type="checkbox"/>	<input type="checkbox"/>	
Provisions and maintenance of firefighting equipment			
Fire hydrant system – installed?	<input type="checkbox"/>	<input type="checkbox"/>	
> Does it provide coverage to all areas?	<input type="checkbox"/>	<input type="checkbox"/>	
> Do the hydrants meet the external hydrant requirement?	<input type="checkbox"/>	<input type="checkbox"/>	
> Does the system meet the water performance requirements needed?	<input type="checkbox"/>	<input type="checkbox"/>	
Static water supply – is it required if the water performance cannot be met?	<input type="checkbox"/>	<input type="checkbox"/>	
> Do the tanks have hardstand areas for fire vehicles?	<input type="checkbox"/>	<input type="checkbox"/>	

RESET

SAVE





Caravan Park **FIRE SAFETY**

GUIDELINE 2012



Checklist

Identification and management of fire hazards

PRINT-FRIENDLY VERSION

	Yes	No	Comments
LP Gas – cylinders installed and secured correctly?	<input type="checkbox"/>	<input type="checkbox"/>	
> Are they vented away from the <i>structure</i> ?	<input type="checkbox"/>	<input type="checkbox"/>	
Electrical safety – is the external power supply compliant?	<input type="checkbox"/>	<input type="checkbox"/>	
> Are the supply leads arranged correctly?	<input type="checkbox"/>	<input type="checkbox"/>	
> Are the leads used to connect to power tagged?	<input type="checkbox"/>	<input type="checkbox"/>	
> Are RCDs installed in <i>structures</i> ?	<input type="checkbox"/>	<input type="checkbox"/>	
> As the park owner do I provide information about electrical safety to park occupants?	<input type="checkbox"/>	<input type="checkbox"/>	
Flammable liquids – do I have any fire protection quantities or manifest quantities of flammable liquids?	<input type="checkbox"/>	<input type="checkbox"/>	
> Has any advice been sought from the Victorian Fire Services about these quantities?	<input type="checkbox"/>	<input type="checkbox"/>	
> Are fuels stored in a manner as not to cause a further hazard?	<input type="checkbox"/>	<input type="checkbox"/>	

RESET

SAVE



Checklist





Checklist

Development and implementation of emergency management plans

PRINT-FRIENDLY VERSION

	Yes	No	Comments
Emergency management plans: Is the EMP displayed in the park? Where is it displayed?	<input type="checkbox"/>	<input type="checkbox"/>	
> Has it been developed based on agreed templates by emergency services?	<input type="checkbox"/>	<input type="checkbox"/>	
> Does it address all of the issues identified?	<input type="checkbox"/>	<input type="checkbox"/>	
> Has it been supplied to local council?	<input type="checkbox"/>	<input type="checkbox"/>	

RESET

SAVE

Other guidance information

PRINT-FRIENDLY VERSION

	Yes	No	Comments
Maintenance: Are the fire safety systems being maintained on a regular basis?	<input type="checkbox"/>	<input type="checkbox"/>	
> Are log books available as proof?	<input type="checkbox"/>	<input type="checkbox"/>	
> Are smoke alarms regularly checked to ensure operation?	<input type="checkbox"/>	<input type="checkbox"/>	

RESET

SAVE



Checklist

Compliance with the legislative requirements

PRINT-FRIENDLY VERSION

	Yes	No	Comments
As a park owner have I met all of the legislative requirements?	<input type="checkbox"/>	<input type="checkbox"/>	
> Do I have a fire safety audit prepared by the fire service?	<input type="checkbox"/>	<input type="checkbox"/>	
> Do I have an updated emergency management plan?	<input type="checkbox"/>	<input type="checkbox"/>	
> Have I supplied these to local council as part of my registration application?	<input type="checkbox"/>	<input type="checkbox"/>	
> Am I meeting my registration obligations?	<input type="checkbox"/>	<input type="checkbox"/>	
> Am I maintaining my fire safety equipment installed within the park?	<input type="checkbox"/>	<input type="checkbox"/>	

RESET

SAVE





References

Country Fire Authority Act 1958

Dangerous Goods Storage and Handling Regulations 2000

Department of Planning and Community Development, *Guide to Victoria's Caravan Park Regulations*, 1 December 2010

Metropolitan Fire Brigades Act 1958

National Construction Code

Planning and Environment Act 1987

Residential Tenancies Act 1997

Residential Tenancies (Caravan Parks and Movable Dwellings Registration and Standards) Regulations 2010

Standards Australia, Australian Standard AS 1596 *The storage and handling of LP Gas*

Standards Australia, Australian Standard AS 1851 *Maintenance of fire protection systems and equipment*

Standards Australia, Australian Standard AS 1940 *The storage and handling of flammable and combustible liquids*

Standards Australia, Australian Standard AS 2419.1 *Fire hydrant installations – system design, installation and commissioning*

Standards Australia, Australian Standard AS 2441 *Installation of fire hose reels*

Standards Australia, Australian Standard AS 2444 *Portable fire extinguishers and fire blankets – selection and location*

Standards Australia, Australian Standard AS 3001 *Electrical installation – Transportable structures and vehicles including their site supplies*

Standards Australia, Australian Standard AS 3745 *Emergency control organisation and procedures for buildings, structures and workplaces*

Standards Australia, Australian Standard AS 3786 *Smoke alarms*

Standards Australia, Australian and New Zealand Standard AS/NZS 3000 *Electrical installations* (known as Australian/New Zealand Wiring Rules)

Standards Australia, Australian and New Zealand Standard AS/NZS 3001 *Electrical installations – relocatable premises (including caravans and tents) and their site installations*

Standards Australia, Australian and New Zealand Standard AS/NZS 3760 *In-service safety inspection and testing of electrical equipment*

Standards Australia, Australian and New Zealand Standard AS/NZ S4360 *Risk Management*

Note: Some of these materials are available on a subscription model. Some materials may be available through your local council or library.